



MTP Series Modular Thermal Printers User Manual

MTP-2822 - 60 mm (2.36 in) paper width
MTP-2832 - 80 mm (3.15 in) paper width
MTP-2242 - 114 mm (4.49 in) paper width
MTP-2283 - 215.9 mm (8.5 in) paper width



Telpar, Inc.

800-872-4886

Fax: 603-742-9938

Website: www.telpar.com

E-mail: info@telpar.com

Warranty

Telpar, Inc. — Printer Limited Warranty

.WARRANTIES AND DISCLAIMERS. Products manufactured by Telpar are warranted against defects in workmanship and materials for a period of twelve (12) months from the date of shipment to the original user, provided the Product (a) remains unmodified, (b) is used only in the United States or Canada, (c) is operated under normal and proper conditions, as Telpar determines in its sole discretion, and (d) Customer provides prompt written notice Telpar of any defects as to parts and/or workmanship to. Telpar may provide an extended warranty on certain Products or components thereof for an additional price determined solely by Telpar and such extended warranty shall only be effective to the extent memorialized in writing by Telpar. Telpar's sole obligation and Customer's exclusive remedy for defective Telpar-manufactured Products is limited to repair or replacement, as Telpar determines in its sole discretion. The warranty described above does not include any labor or service costs for removing or replacing parts, or any shipping charges. Any repair performed by Telpar under this warranty does not extend the original warranty period of any Product. This warranty shall not apply to any Product which has: (i) been repaired or altered, except by Telpar; (ii) not been maintained in accordance with all of the operating or handling instructions supplied by Telpar, or (iii) been subjected to misuse, willful acts, abuse, tampering, negligence or accident, unusual physical or electrical stress, as Telpar determines in its sole discretion. Customer acknowledges that Telpar provides no warranty for any third party materials and Telpar is not responsible and will have no liability for any items or services provided to Customer by any person or entity other than Telpar. Telpar's duty to perform under any warranty may be delayed, at Telpar's sole option, until Telpar has been paid in full for all Products purchased by Customer. No such delay shall extend the warranty period. To obtain assistance under this limited warranty, Customer should contact the selling agency or write to: Telpar, Warranty Claims Department, 187 Crosby Road, Dover, NH, 03820, U.S.A. Telephone: 800-872-4886 or fax: 603-742-9938. No person (including, without limitation, any agent, salesman, dealer or distributor) has the authority to act on behalf of Telpar to expand Telpar's obligation beyond the terms of this express warranty, or to state that the performance of the Product is other than published by Telpar. For Products not manufactured by Telpar, to the extent permitted Telpar assigns to Customer the benefits of any warranties provided to Telpar by the manufacturer(s) of the Product. THE FOREGOING IS A LIMITED WARRANTY AND IT IS THE ONLY WARRANTY PROVIDED BY TELPAR. TELPAR DISCLAIMS ALL WARRANTIES, EXPRESS OR IMPLIED, INCLUDING ALL IMPLIED WARRANTIES OF MERCHANTABILITY AND FITNESS FOR A PARTICULAR PURPOSE AND ALL WARRANTIES OR INDEMNITIES FOR PATENT OR COPYRIGHT INFRINGEMENT. IN NO EVENT SHALL TELPAR BE LIABLE FOR ANY INDIRECT, INCIDENTAL, SPECIAL OR CONSEQUENTIAL DAMAGES, INCLUDING LOSS OF PROFITS, REVENUE, DATA, OR USE, INCURRED BY CUSTOMER OR ANY THIRD PARTY, WHETHER IN AN ACTION IN CONTRACT OR TORT, ARISING OUT OF OR RELATED TO THIS AGREEMENT, EVEN IF TELPAR OR ANY OTHER PERSONS HAS BEEN ADVISED OF THE POSSIBILITY OF SUCH DAMAGES. TELPAR'S LIABILITY FOR DAMAGES HEREUNDER FOR ANY CAUSE WHATSOEVER SHALL IN NO EVENT EXCEED THE AMOUNTS RECEIVED BY TELPAR FROM THE CUSTOMER FOR THE PRODUCTS. TELPAR SHALL NOT BE RESPONSIBLE FOR ANY LOSS, DAMAGE OR EXPENSE OF ANY KIND CAUSED DIRECTLY OR INDIRECTLY BY THE USE OR PERFORMANCE OF THE PRODUCT PROVIDED HEREUNDER.

Upon inspection, Telpar will make necessary repairs or replacement and return the merchandise, shipping prepaid.

Table of Contents

1	General	5
1.1	Applications	5
1.2	Standard Features.....	5
1.3	Power Supply Requirements.....	6
1.3.1	External Power Supply (supplied separately)	6
1.3.2	Voltage: 24 VDC ±5%.....	6
1.3.3	3-Pin Hosiden Connector on Printer for Power Supply Connection	7
1.4	Telpar Roll Paper for MTP Series.....	7
1.5	Document Presenter Option.....	7
2	Operator Instructions	8
2.1	Unpacking and Inspection.....	8
2.2	Printer Sensors	8
2.2.1	Sensors on the MTP-2822, MTP-2832, and the MTP-2242.....	8
2.2.2	Sensors on the MTP-2283	10
2.3	Paper Loading	12
2.3.1	Side-Loading Roll	12
2.3.2	Top Loading Roll	12
2.4	Clearing a Paper Jam.....	13
2.4.1	Lifting the Print Head and cutter (MTP-2822, MTP-2832, MTP-2242).....	13
2.4.2	Lifting the Print Head of the MTP-2283.....	14
3	Manual Operation and General Operational Tests	15
3.1	Paper Cut and Paper Feed Buttons	15
3.2	Self Test Mode and Burn-in Mode	15
3.2.1	Self Test	15
3.2.2	Factory Burn-in Mode	15
4	Printer Control.....	16
4.1	DIP Switch Settings and Print Darkness Adjustment.....	16
4.2	Control Codes and Control Sequences.....	18
4.2.1	General Usage Print Commands	18
4.2.2	Descriptions of Commands	23
4.2.2.1	Status commands	23
4.2.2.2	Set Print Mode.....	24
4.2.2.3	Printer Reset.....	24
4.2.2.4	Telpar's Window Commands.....	24
4.2.2.5	Bit Image (BI) Graphics Mode Commands	25
4.2.2.6	Print Bar Code Command.....	25
4.2.2.7	Bar Code 128 definitions.....	26

- 4.3 Serial (RS-232C) Interface28**
 - 4.3.1 Serial (RS-232C) Interface Specification..... 28
 - 4.3.2 Serial I/O Connector..... 28
 - 4.3.3 Optional MTP Serial Adapter Cable 29
- 4.4 Parallel Interface (IEEE-1284).....30**
 - 4.4.1 Parallel I/O Connector, IEEE-1284 Type C 30
 - 4.4.2 Optional MTP Parallel Adapter Cable.....31
- 4.5 USB Interface32**
- 4.6 Ethernet Interface32**
- 4.7 Printer Drivers32**
- 5 Detailed Specifications33**
 - 5.1 MTP-2822, MTP-2832, and MTP-2242 Detailed Specifications33**
 - 5.2 MTP-2283 Detailed Specifications.....34**
 - 5.3 Character Sets - Print Samples.....35**
 - 5.4 MTP-2822 Standard Printer Drawing40**
 - MTP-2822 Presenter Printer Drawing.....41**
 - 5.5 MTP-2832 Standard Printer Drawing42**
 - MTP-2832 Presenter Printer Drawing.....43**
 - 5.6 MTP-2242 Standard Printer Drawing44**
 - MTP-2242 Presenter Printer Drawing.....45**
 - 5.7 MTP-2283 Standard Printer Drawing46**
 - MTP-2822 Presenter Printer Drawing.....47**
- 6 Troubleshooting48**
 - 6.1 General Troubleshooting.....48**
 - 6.2 LED Diagnostics and Error Detection Codes.....49**
 - 6.3 LED Error Code Definitions Table.....50**

1 General

(For detailed specifications for each of the individual printers, please see Section 5 in this manual.)

The MTP series of modular thermal printers is designed specifically for the high performance, size and durability requirements of cut and drop (or cut and present with optional Document Presenter) applications. The compact size and high performance characteristic, coupled with its rugged design, makes it ideal for the kiosk environment.

These models make up the MTP Series covered in this manual:

- MTP-2822 - 60 mm (2.36 in) paper width
- MTP-2832 - 80 mm (3.15 in) paper width.
- MTP-2242 - 114 mm (4.49 in) paper width.
- MTP-2283 - 215.9 mm (8.5 in) paper width.
- All models above may be ordered with an optional Document Presenter.

1.1 Applications

- Kiosks
- Automated Teller Machines (ATMs)
- Parking ticket dispensing
- Gaming receipts

1.2 Standard Features

- Direct thermal printing
- Interfaces: Serial (RS-232), Parallel and USB interfaces all on the same printer
- Auto Cutter: full cut/partial cut under software control is standard
- All metal construction
- Adjustable paper low sensor
- Paper auto load function
- ESC/POS^{® 1} The commands conform to ESC/POS
- LEDs visible and DIP switches accessible without removing cover
- International character set: U.S.A., France, Germany, England, Denmark (2 choices), Sweden, Italy, Spain (2 choices), Japan, Norway, Latin America and Korea
- Barcode embedded symbologies: UPC-A, UPC-E, EAN 13, EAN 8, 3of 9, ITF, CODABAR, and Code 128
- Two resident font sizes
- Code pages 437, 850, 858, 860, 863, 865, and WPC 1252.
- Bit image mode
- Reverse video mode
- Black mark sensing (TOF mode)

¹ ESC/POS is a registered trademark of SEIKO EPSON Corp.

1.3 Power Supply Requirements

1.3.1 External Power Supply (supplied separately)

Use a Listed/Certified Power Supply.
Follow local wiring codes for external wiring.

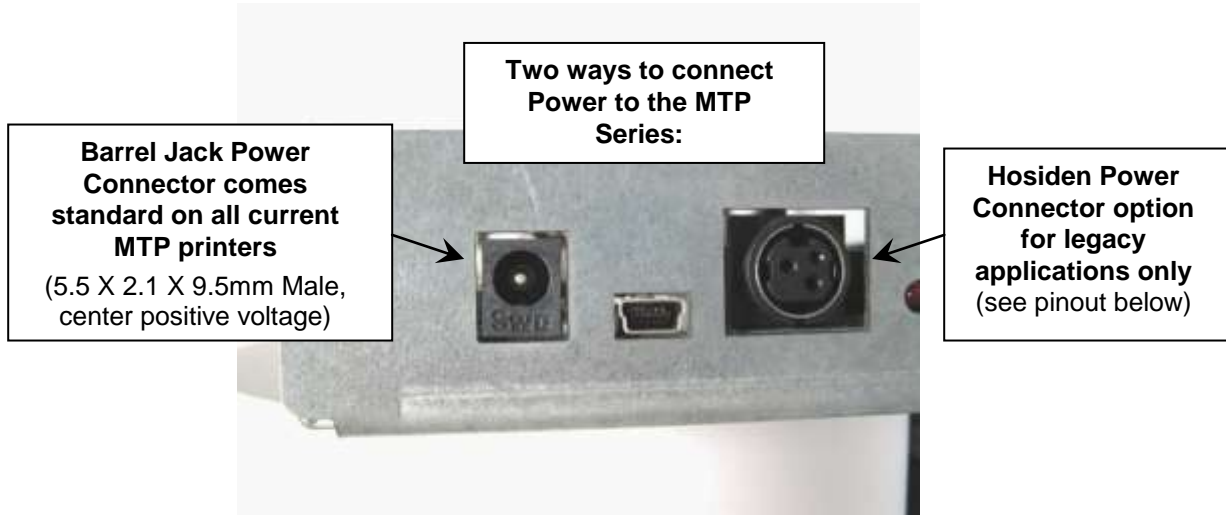

1.3.2 Voltage: 24 VDC ±5%

These printers operate using high speed currents at a low duty cycle. Typically, a switching power supply rated at 24 Volts DC, 2 Amps (50 Watts) is all that is needed **as long as the power supply selected can provide the maximum peak current for the Printing Rate as indicated in the table below.** For more detailed printer specifications, please reference Section 5 in this manual.

Power Supply Option (Telpar Part Number 103929-0401): Telpar offers a power supply suitable for use with all of the latest MTP series printers (Not Compatible with the older, legacy MTP printer series). This power supply's female plug fits the printers' barrel jack connector and also provides a built-in ON/OFF switch near the connector end.

Current (A) for Printer Head			
Printing Rate	Printer Model	Avg	Peak
Solid Black-out (considered the " worst case " scenario)	MTP-2822	1.75	4
	MTP-2832	2.25	5
	MTP-2242	3	7
	MTP-2283	3	10
Typical ASCII text (considered closest to the typical, normal operation for most users)	MTP-2822	1	2.5
	MTP-2832	1.25	2.5
	MTP-2242	1.5	3.5
	MTP-2283	1.0	3

1.3.3 3-Pin Hosiden Connector on Printer for Legacy Power Supply Connection

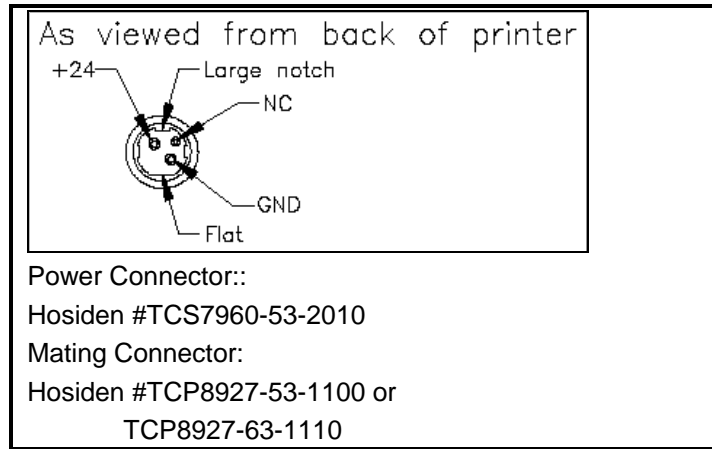

3-Pin Hosiden Power Supply Connector

1.4 Telpar Roll Paper for MTP Series

Thermal sensitive coating is on the “inside” of the roll.

- For MTP-2822: 152 mm (6 in) outside diameter, 60 mm (2.36 in) wide, approximate length 180 m (590 ft) Telpar P/N 251410-0602
- For MTP-2832: 152 mm (6 in) outside diameter, 80 mm (3.15 in) wide, approximate length 180 m (590 ft) Telpar P/N 251103-8006
- For MTP-2242: 152 mm (6 in) outside diameter, 114 mm (4.49 in) wide, approximate length 180 m (590 ft) - Telpar P/N 251410-0604
- For MTP-2283: 152 mm (4.5 in) outside diameter, 215.9 mm (8.5 in) wide, approximate length 104 m (340 ft) - Telpar P/N 751221-0041
- For MTP-2283: 203 mm (8 in) outside diameter, 215.9 mm (8.5 in) wide, approximate length 398 m (1,307 ft) - Telpar P/N 751221-2080

Specific to Thermal Printers: Telpar, Inc. does not warranty damages to the thermal print head as a result of printing with thermal paper not specified or approved by Telpar, Inc.

1.5 Document Presenter Option (Presenter dimensions can be found in Section 5 – Printer Drawings)

The MTP Printer Series can be ordered with an optional document presenter which attaches to the front of the printer (just after the cutter mechanism). The purpose of the document presenter option is to prevent a person from making physical contact with a document until the document has been completely printed and cut. This decreases the likelihood of someone purposely or accidentally causing a paper jam or smearing the printed information by pulling on the exiting document before it has finished printing. This option is especially useful when printing long documents.

Preventing human contact with a document during a printing operation is accomplished by allowing the presenter to hold the leading edge of the document (preventing the document from exiting the printer) while the remainder of the document is being printed. A paper loop will form below the presenter assembly while document printing is in progress. Finally, after the completed document is cut, the presenter ejects the document up to the trailing edge of the paper which it holds so that the customer may take the document from the presenter exit. The printer can be configured to retract the document if the customer has not removed it after a specified passage of time.

Check with our sales team to see if a Document Presenter would be beneficial to your application.

2 Operator Instructions

2.1 Unpacking and Inspection

Carefully unpack and inspect your printer for any damage that may have occurred in transit. Should any damage have occurred, notify Telpar, Inc., save the shipping carton and packing materials, and file a damage claim with the carrier. Specify the nature and the extent of the damage. Before installing or operating the printer, check the following:

- Printer mechanism and paper path are clear of all packing materials or other foreign matter.
- Paper is installed. DO NOT OPERATE the printer without paper. Refer to Section 2.3 - Paper Loading for paper loading instructions.

2.2 Printer Sensors

The MTP series of printers use infrared, reflective sensors to detect when the paper roll is getting low, when paper is present under the print head, and when paper has entered the document presenter (if your printer has the document presenter option). These sensors should be periodically cleaned from dust and other debris which will accumulate on them over time. Cleaning periodically will help prevent intermittent, false triggering of the sensors which result in system downtime. It is recommended that pressurized air be used to clean the sensor surfaces as shown below.

2.2.1 Sensors on the MTP-2822, MTP-2832, and the MTP-2242

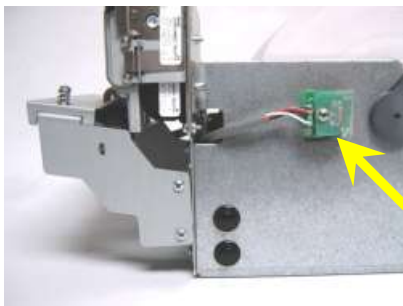

MTP-2822, MTP-2832, and MTP-2242 External Sensor Option

The External Paper Low Sensor option, shown here, can be physically rotated to detect various diameter sizes via a rounded cutout in the chassis. Printer status feedback will indicate whether or not the sensor detects the roll as the roll's diameter decreases with use.

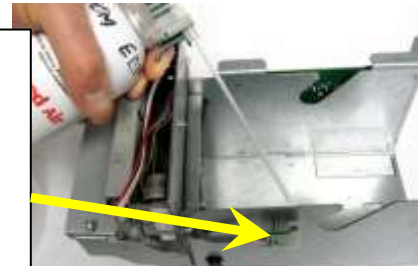

The sensor surface can be cleaned by blowing pressurized air over the sensor face through the rounded slot in the chassis as shown above.

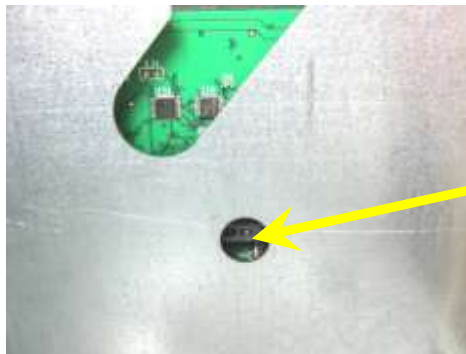

MTP-2822, MTP-2832, and MTP-2242 Internal Sensor

The fixed, Internal Paper Low Sensor, shown here, comes standard on these printers, and detects when the paper roll is almost depleted. Printer status feedback will indicate whether or not the sensor detects the roll as the roll's diameter decreases with use. The sensor surface can be cleaned by blowing pressurized air over the sensor face through the round hole in the chassis. Internal **OR** External Paper Low Sensor detection can be selected via the state of DIP Switch, position 6 on the printer's circuit board (Section 4).

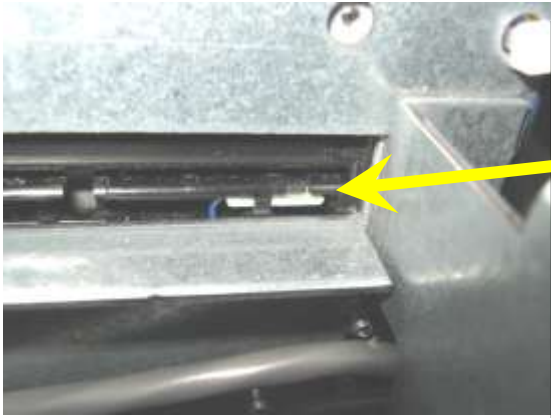

MTP-2822, MTP-2832, and MTP-2242 Paper Present Sensor

The Paper Present Sensor, shown here, is part of the print head mechanism and is located at the front of the mechanism's paper entry slot. This sensor detects if paper is present in the print head mechanism. If there is no paper presently in the printer, and paper is fed through the entry slot, the printer will perform an auto feed operation. If paper is in the printer mechanism and the paper supply runs out, the printer will indicate an out of paper status. This sensor can be cleaned by blowing pressurized air over the sensor face through the paper entry slot.

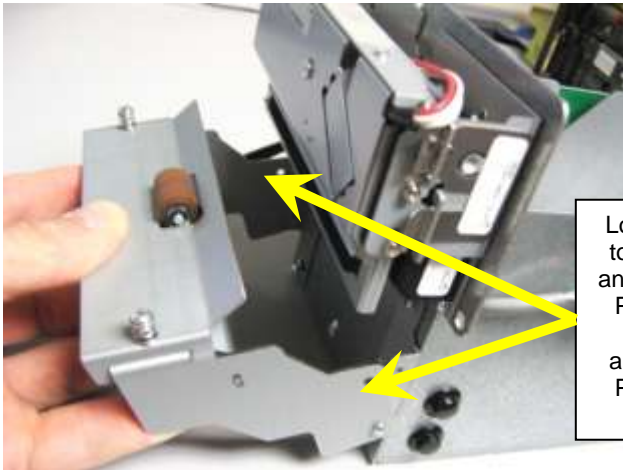

Loosen two top screws and pivot the Presenter down to access the Presenter Sensor.

The Presenter Sensor may then be cleaned through this rectangular cutout in the chassis.

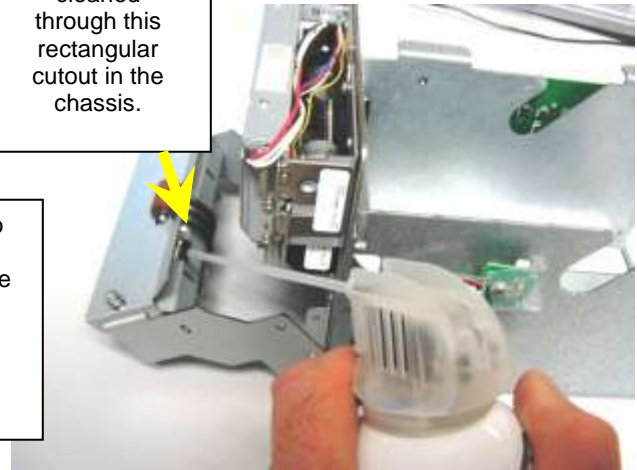

DOCUMENT PRESENTER OPTION ONLY – MTP-2822, MTP-2832, and MTP-2242

The Presenter Sensor (location shown above) detects when the leading edge of the paper has entered far enough into the presenter section to stop the presenter motor from turning and thereby preventing the paper from being ejected until the printer prints and cuts the document. It also detects if the document has been successfully ejected (or retracted) from the presenter section after the document has been printed and cut. To access the Presenter Sensor, loosen the presenter's top two mounting screws and pivot the presenter section down as shown above. The Presenter Sensor may then be cleaned through the rectangular cutout in the chassis.

2.2.2 Sensors on the MTP-2283

MTP-2283: Accessing the Paper Present Sensor

The MTP-2283 Paper Present Sensor is located under the print head mechanism and therefore the print head must be raised to access this sensor. The MTP-2283's print head is raised by first lightly lifting the cutter release latch on the center top of the printer to let the cutter mechanism pivot downward (left picture). Next, gently flex back the two spring clips on each side of the print head until the clips just clear the spring pins (middle picture). Finally, once both spring clips are free from the clip pins, rotate the print head up (right picture).



MTP-2283 Paper Present Sensor

The MTP-2283 Paper Present Sensor is located below the rectangular cutout under the print head mechanism as shown. This sensor detects if paper is present in the print head mechanism. If there is no paper presently in the printer, and paper is fed through the entry slot, the printer will perform an auto feed operation. If paper is in the printer mechanism and the paper supply runs out, the printer will indicate an out of paper status. This sensor can be cleaned by blowing pressurized air over the sensor face through the Rectangular cutout in the chassis.



MTP-2283 Paper Low Sensor

The Paper Low Sensor, shown here, is mounted on the paper roll holder. It detects when the paper roll is almost depleted. Printer status feedback will indicate whether or not the sensor detects the roll as the roll's diameter decreases with use. The sensor surface can be cleaned by blowing pressurized air over the sensor face through the hole in the roll side of the chassis.

DOCUMENT PRESENTER OPTION ONLY – MTP-2283

The Presenter Sensor (location shown below) detects when the leading edge of the paper has entered far enough into the presenter section to stop the presenter motor from turning and thereby preventing the paper from being ejected until the printer prints and cuts the document. It also detects if the document has been successfully ejected (or retracted) from the presenter section after the document has been printed and cut. To access the Presenter Sensor, remove the presenter's top paper guide first. To do this, lightly flex back the spring clip on the side of the presenter until the guide's tabs are just fully exposed (shown below). Then lift and remove the guide from the presenter (right picture).



To access the Presenter Sensor on the MTP-2283, you must remove the presenter's top paper guide first. To do this, lightly flex back the spring clip on the side of the presenter until the guide's tabs are just fully exposed (shown above). Then lift and remove the guide from the presenter (right picture).

2.3 Paper Loading

2.3.1 Side-Loading Roll

The MTP-2822 and MTP-2832 printers are configured as side-loading units. Slide the roll of paper over the spindle so that the paper will feed into the print mechanism from the bottom of the roll (thermal coated side **up**).

To load paper, power the printer and feed the straight edge of the paper into the print mechanism's paper in-feed slot. **NOTE:** The printer does not have an ON / OFF Switch. Inserting paper will result in the automatic loading of paper once the leading edge of the paper covers the Paper Present Sensor in the mechanism (Section 2.2.1). Ensure that the paper is installed correctly and feeding properly with the **thermal side facing up**.

2.3.2 Top Loading Roll

The MTP-2242 and MTP-2283 printers are configured as a drop in loader (as shown below). Load the roll of paper by placing the spindle inside the roll of paper and slide the spindle into the slots. The paper must feed into the print mechanism from the bottom of the roll (thermal coated side **up**). To load paper, power the printer and feed the straight edge of the paper into the paper guide. **NOTE:** The printer does not have an ON / OFF Switch. Inserting paper will result in the automatic loading of paper once the leading edge of the paper covers the Paper Present Sensor in the mechanism (Section 2.2.1). Ensure that the paper is installed correctly and feeding properly with the **thermal side facing up**.

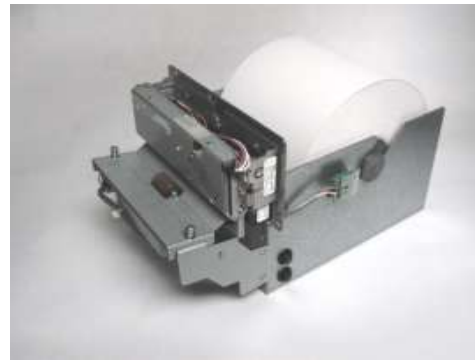

MTP-2242 Paper loading



MTP-2283 Paper loading

2.4 Clearing a Paper Jam

In the event of a paper jam condition do not force paper into the unit, or try to pry the paper out of the unit, this may damage the thermal print mechanism. Instead, lift the print head up, off the paper to clear a jam as shown below. **Caution should be exercised when working next to the cutter mechanism, the blades are sharp and may cause serious injury!** Therefore, it is recommended to **unplug** the Printer before clearing a jam!

2.4.1 Lifting the Print Head and Cutter Sections of the MTP-2822, MTP-2832, and MTP-2242

The MTP-2822, MTP-2832, and MTP-2242's Head Up lever is located by the Paper Feed knob as shown below. Rotating the lever to the fully down position allows the print head to physically contact the paper while also closing an interlock switch which tells the printer it is ready to print – you will not be able to print if the lever is up. When the lever is in the middle position, it reduces pressure between the print head and the print platen roller for easier manual feeding. In the fully up position, the lever lifts the print head off of the platen roller for manually inserting paper or for clearing a paper jam. Both the middle and up positions signal the microprocessor that the head is up so that no printing will occur.

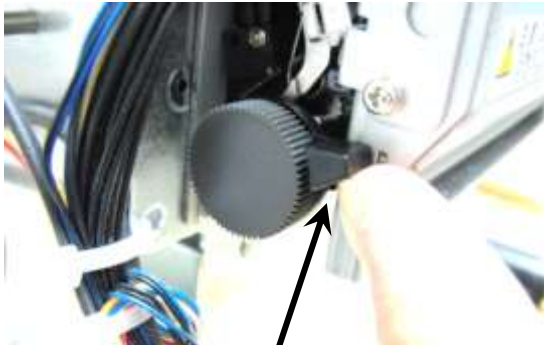

Head Up Lever shown in the “up” or open position. Pertains to the MTP-2822, the MTP-2832, and the MTP-2242



Head Up Lever shown in the “down” or closed position. Pertains to the MTP-2822, the MTP-2832, and the MTP-2242

The MTP-2822, MTP-2832 and MTP-2242 have a cutter mechanism that can easily be rotated up away from the print head to further assist in clearing jams that occur between the print head and the cutter. However, if the printer has a Document Presenter and a paper jam exists between the print head and the cutter or between the cutter and the presenter, the presenter section must be pivoted down and out of the way before the cutter section can be raised. To do this, loosen the presenter's top two mounting screws and pivot the presenter section down as shown below in the left-hand picture. The cutter section can then be raised as shown in the right-hand picture.

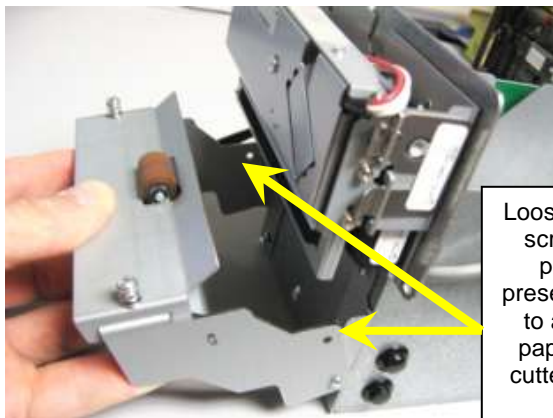

Loosen two top screws and pivot the presenter down to access a paper jam in cutter section.

Once the presenter is out of the way, the cutter section can be raised.

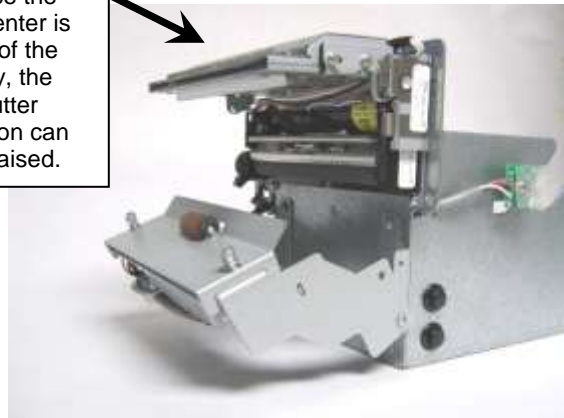

2.4.2 Lifting the Print Head of the MTP-2283

The MTP-2283's print head is lifted via releasing three spring clips as shown below. Lifting the head will allow you full access for clearing jams in the printing section as well as access to the Paper Present Sensor which may need to be cleaned from paper dust from time-to-time. When the print head of the MTP-2283 is in the up position, be careful not to physically contact the actual print head element itself (element looks like a long, dark stripe on the bottom of the head) as you may easily damage it. The printer will not be able to print or automatically feed paper with the head up. When closing the print head, make sure that all three spring clips are fully secured around their respective spring pins.

The MTP-2283's print head is raised by first lightly lifting the cutter release latch on the center top of the printer to let the cutter mechanism pivot downward.



Next, gently flex back the two spring clips on each side of the print head until the clips just clear the spring pins as shown below.



Finally, once both spring clips are free from the clip pins, rotate the print head up as shown. A paper jam in the print head section can now be easily cleared.



If the printer has a Document Presenter and a paper jam exists between the cutter and the presenter, then the top section of the presenter may be removed to provide easy access to the jam. To do this, lightly flex back the spring clip on the side of the presenter until the guide's tabs are just fully exposed (shown below in left-hand picture). Then lift and remove the guide from the presenter (right picture).



Document Presenter's top guide plate can be easily removed to allow access to paper jams in the cutter / presenter section.

3 Manual Operation and General Operational Tests

3.1 Paper Cut and Paper Feed Buttons

The MTP series of printers have two external, momentary push-buttons that allow the operator to manually feed and cut paper. The locations of these buttons are shown below. When the Feed Button is pressed, the printer will feed paper until the Feed Button is released. When the Cut Button is pressed and released, the printer will feed and cut one short section of paper.

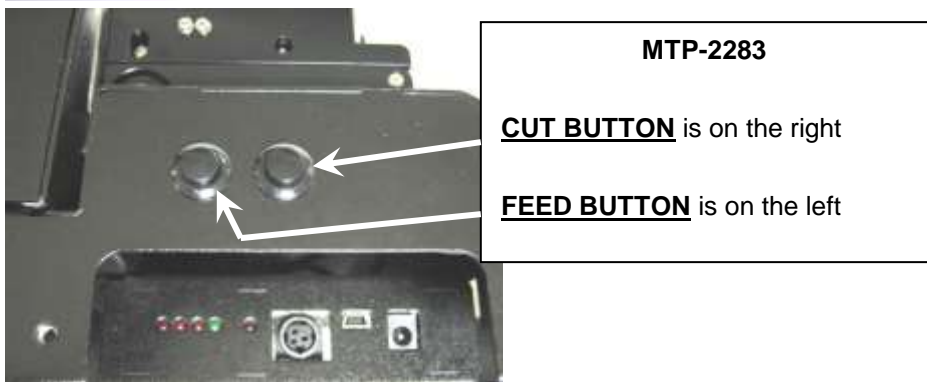
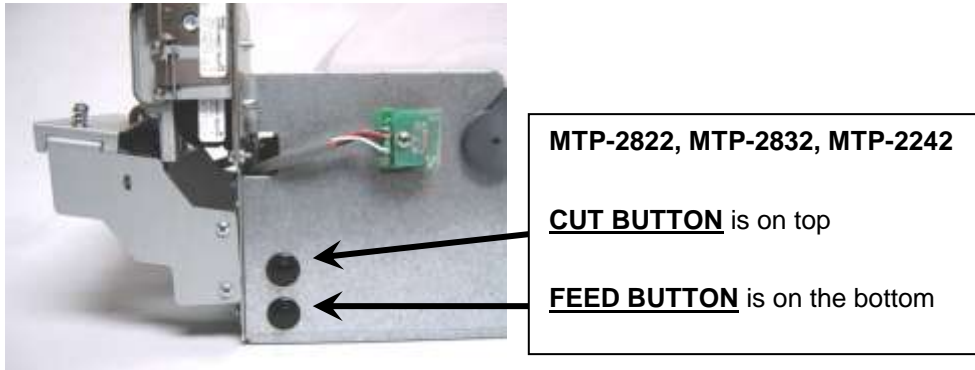

3.2 Self Test Mode and Burn-in Mode

The MTP series has a self-test and Burn-in mode that will print and cut sample documents. All electrical and mechanical portions of the printer are exercised and checked by this action (except for the communication interface components). The self-test printout also shows pertinent information pertaining to the current printer setup.

3.2.1 Self Test

NOTE: The printer does not have to be connected to a host (computer, PLC, or other controller) to perform a Self Test. To place the unit into self-test mode: remove power from the printer, then press and hold the FEED button (see above). Next, return power to the printer, then release the paper feed switch after hearing one beep. The printer will print a Self Test form showing pertinent information pertaining to the current setup and sample text and barcodes.

3.2.2 Factory Burn-in Mode

NOTE: The printer does not have to be connected to a host (computer, PLC, or other controller) to enter the Factory Burn-in Mode. If the Feed button is held for five beeps after power is applied to the printer, the printer will enter the Factory Burn-In Mode. Fifty shorter sheets will be printed.

4 Printer Control

4.1 DIP Switch Settings and Print Darkness Adjustment

Note: Both the Printer's DIP Switch and Print Darkness Adjustment can be accessed through the cutout in the metal chassis as shown:



DIP Switch Settings: Each Printer in the MTP series of printers has a DIP Switch located on the main circuit board (see photo below). The DIP Switch contains a bank of eight individual switches, each of which controls some aspect of the printer and are described in the table below. The switches can slide up into the “ON” position or down into the “OFF” position (the picture below shows switches 1, 2, and 3 in the “OFF” position, and switches 4, 5, 6, 7, and 8 in the “ON” position). A small tip screwdriver or even a pen tip may be used to change the position of the switches.

The DIP Switch on each type of printer can be accessed through a cutout hole on the metal circuit board cover – therefore, DIP Switch changes can be made without removing the cover. **IMPORTANT NOTE:** If you make any changes to the DIP Switch settings, you must first cycle power to the printer in order for the changes to take place.

Print Darkness Adjustment: Control R35 on the circuit board is the Print Darkness (or Print Density) Control (see photo below). Clockwise rotation of the control increases print darkness, but also consumes more current and shortens the life of the print head. Therefore, it is recommended that the darkness level be increased to the point that just meets the desired darkness level under the normal ambient operating conditions for the printer application.

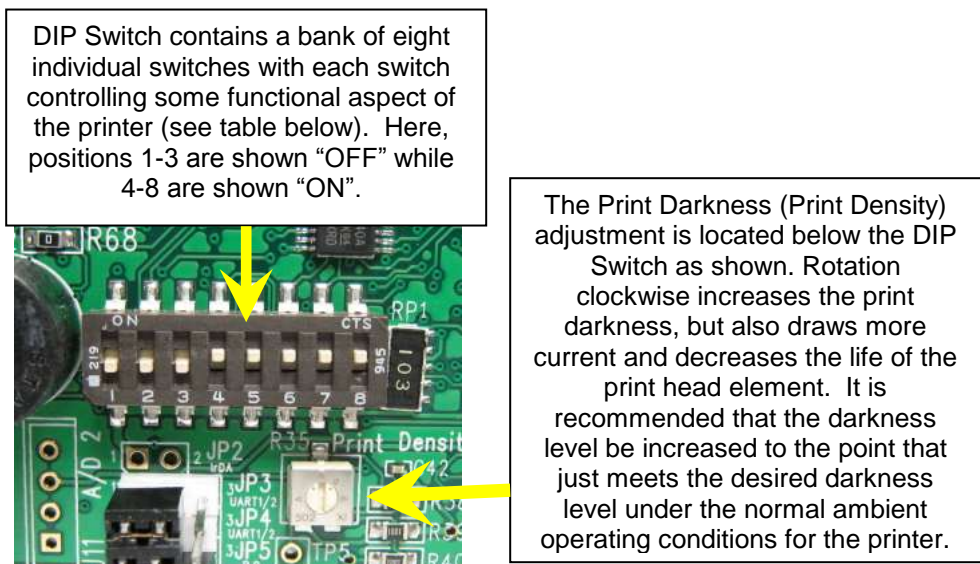

DIP Switch Position	Printer Function based on State of Switch
1	<p>OFF = Normal Print Mode (normal operating mode for printer) ON = Flash Memory Upload Mode</p>
2	<p>OFF = Paper cutter disabled (will not cut paper) ON = Paper cutter enabled (will cut paper)</p>
3	<p>Reserved for future use</p>
4	<p>OFF = Document Presenter disabled (no document presenter option on the printer) ON = Document Presenter enabled (printer has the document presenter option)</p>
5	<p><u>This setting pertains to models with the document presenter option only</u></p> <p>OFF = Presenter paper loop enabled (prints first, cuts second, then delivers) ON = Presenter paper loop disabled (delivers document while printing, then cuts)</p>
6	<p><u>Paper Roll Low Sensor (MTP-2822, MTP-2832, MTP-2242) → select which sensor to use:</u></p> <p>OFF = Use Internal Paper Low Sensor on the board (standard configuration) ON = Use External Paper Low Sensor on chassis side (optional configuration)</p>
7	<p>Reserved for future use</p>
8	<p><u>This setting pertains to the MTP-2283 only</u></p> <p>OFF = Low Current Mode disabled (uses more current, faster printing) ON = Low Current Mode enabled (uses less current, slower printing)</p>

4.2 Control Codes and Control Sequences

4.2.1 General Usage Print Commands

General Usage Print Commands			
Name	Command ASCII	Command hex	Description
Tab	HT	09	Move the print position to the next horizontal tab position. See ESC D. If a TAB is received and there are no more tab positions set on the current line, the TAB command is ignored. If the TAB will exceed the right margin, an auto-print is performed and the print position is set to the start of the next line.
Line feed	LF	0A	Data on the current line is printed, paper is fed one line based on the current line spacing, and the print position is set to the left margin. If the current line spacing is set to less than the current font height then paper is fed to print the current font height (see ESC 2, ESC 3 +n, and ESC C +n).
Form Feed	FF	0C	Feed paper to end of page as defined by the default page length of 11 inches or as modified by the US C command. If TOF mode is enabled (DIP switch 2 position 1 or ESC c 1 +n)) then paper is fed until the next BLACK MARK is detected. To advance to the BLACK MARK if TOF mode is not enabled use the GS FF command.
DLE	DLE	10	Data Link Escape Sequence Header.
Enable Auto Status Back	DLE A +n1 +n2	10 41 +n1 +n2	+n1 and +n2 define a mask to enable the transmission of the STATUS bytes when a user defined event occurs. See Section 0 - Status commands. Default = 00 00 (ASB disabled).
Buffered STATUS request	DLE B	10 42	The STATUS bytes are transmitted when this command is processed out of the receive buffer. See Section 0 - Status commands.
Real time STATUS request	DLE R	10 52	The STATUS bytes are transmitted when this command is received by the printer. See Section 0 - Status commands.
User selected data string	DLE U +n1 +n2	10 55 +n1 +n1	When DLE U +n1 +n2 is processed out of the receive buffer, the printer will transmit DLE U +n1 +n2 back to the host.
ESC	ESC	1B	ESCAPE Sequence Header.
GS	GS	1D	GROUP SEPARATOR Sequence Header.
US	US	1F	UNIT SEPARATOR Sequence Header.
Reverse Video ON	ESC RS	1B 1E	Printing is reversed to white characters on black background. Reverse video requires more power to print and is less readable. (Same as GS B 01).

Telpar, Inc. MTP Series Receipt Thermal Printer User Manual

Name	Command ASCII	Command hex	Description
Reverse Video OFF	ESC US	1B 1F	Printing is set to default mode of black print on white background. (Same as GS B 00).
Set Print mode	ESC ! +n	1B 21 +n	Set Print mode = font A or B, Double high, Double wide.
Select Bit Image mode	ESC .: +m +n1 +n2 +d1~dn	1B 2A +m +n1 +n2 (data)	Select Bit Image mode. +m = ?. n2*256 + n1 = Number of DOT LINES of data to follow. (data) = the amount of data required to complete the sequence. Telpar does not fully support this command. Please refer to US * command which follows.
Underline	ESC - +n	1B 2D +n	Bit 0 of n = 0 turns underlining OFF. Bit 0 of n = 1 turns underlining ON. Default is OFF.
Set 1/6" line spacing	ESC 2	1B 32	Set 1/6 inch line spacing.
Set Line feed pitch	ESC 3 +n	1B 33 +n	Set line spacing to n dot lines. If the n specified is less than the height to print text using the currently selected character set then printing will cause enough paper feeds to print the entire line but a print command with no data in the buffer will cause paper to feed by this amount. Default is 1/8 inch
Printer reset	ESC @	1B 40	Initialize. See Section 4.2.2.3
Set page length	ESC C +n	1B 43 +n	Set page length to n character lines using the current font. Overwrites the page length defined by US C.
Set Horizontal Tab positions	ESC D +d1~dn NUL	1B 44 (data) 00	Set from 1 to 32 tab positions in the current character size. Data values range from 1 to 255 in ascending order. The NUL character (00 hex) terminates this command if less than 32 tab settings are being set. If a data value is less than the previous data value, this command is terminated. ESC D NUL clears all tab positions. Default is every 8 columns. Print after a tab starts in the column following the tab setting specified.
Forward paper feed for n dot lines	ESC J +n	1B 4A +n	Feed paper n dot lines. If there is data in the buffer, it is printed and paper is fed the difference of the +n and the amount needed to print the data. Range = 0 to 255 dec.
Select International character set	ESC R +n	1B 52 +n	Select international character set. Range = 0 through 15 dec. See International Character Sets for characters affected for each character set.
Select justification for bar code	ESC a +n	1B 61 +n	n=00hex, left justify. n=01hex, center justify. n=02hex, right justify. GS L, GS W, and ESC \ will also affect the bar code justification.

Name	Command ASCII	Command hex	Description
Select paper type	ESC c 1 +n	1B 63 31 +n	Bit 0 = 0, Normal paper. Bit 0 = 1, TOF (Black Mark sensor) enabled. Default is based on Dip switch 2 position 1.
Paper sensor to output PE signal	ESC c 3 +n	1B 63 33 +n	Command is not implemented, all four bytes will be ignored.
Paper sensor to stop printing	ESC c 4 +n	1B 63 34 +n	Command is not implemented, all four bytes will be ignored.
Select CODE PAGE	ESC t +n	1B 74 +n	n = 0, code page 437 (standard USA). n = 2, Code page 850 (Multilingual). n = 3, Code page 860 (Portuguese). n = 4, Code page 863 (Canadian-French). n = 5, Code page 865 (Nordic); n=10 hex, WPC1252; n=13 hex, Code page 858 (Multilingual with Euro character)
Feed to Top of Form	GS FF	1D 0C	If TOF mode is disabled (DIP switch 2 position 1 or ESC c 1 +n) then paper is fed until the trailing edge of the Black Mark sensor is detected, the current page length is reached, or the printer runs out of paper.
Select character size	GS !	1D 21 +n	Bits 7,6,5,4 for width, Bits 3,2,1,0 for height. Can select 1,2,4, or 8 times normal size. 0hex = 1X size, 1hex = 2X size, 2hex = 4X size, and 3hex = 8X size.
Reverse video	GS B +n	1D 42 +n	Bit 0 of n = 1 causes Reverse Video to be printed (same as ESC RS). Bit 0 of n = 0 turns Reverse Video off (same as ESC US).
HRI position	GS H +n	1D 48 +n	Select HRI printing position for bar codes, n = 00hex no HRI printed. n = any value other than 00hex, HRI printed below the bar code.
Set left margin	GS L +nH +nL	1D 4C +nH +nL	Sets the left margin to nH*256 + nL dot positions from the left side of the print head. Default = 0 (leftmost dot). The value being set must be equal to or less than the right margin minus 80 dots. If the margin is set to any invalid value this command is ignore. Range = 0 to Right Margin - 80.
Paper cut	GS V +n +m	1D 56 +n +m	If n = 0 (either 00hex or 30hex) a full cut is performed and the +m byte is not needed. If n = 1 (either 01hex or 31hex) a partial cut is performed and the +m byte is not needed. If n is a capital A (41hex) then paper is fed for m dot lines and then a full cut is performed. If n is a capital B (42hex) then paper is fed for m dot lines and then a partial cut is performed. If a presenter is installed, only full cuts are performed.

Name	Command ASCII	Command hex	Description
Set Right Margin	GS W + nH + nL	10 57 + nH + nL	Set the right margin to nH*256 + nL dot positions from the left side of the print head. Default = maximum dot count for the printer mechanism minus 1. The value being set must be equal to or greater than the left margin plus 80 dots. If the margin is set to any invalid value this command is ignore. Range = Left Margin +80 to rightmost dot.
HRI font	GS f	1D 66 +n	Not implemented, the controller selects a font and size to best fit under the bar code being printed.
Set Bar code height	GS h +n	[1D 68 +n	Set the bar code height in dots. Default = 64. Range - 1 to 255 dec.
Bar code printing	GS k +m +n +d1~dn	[1D 6B +m +n (DATA)]	Selects the bar code type and prints. See Section 4.2.2.6 – Print Bar Code Command.
Set Bar code magnification	GS w +n	[1D 77 +n]	Set the width of the bars used to print bar codes. The width of a narrow bar is set to n. Range = 1 to 8. Default = 2. A setting of n=1 prints a bar code so small it is possibly not readable..
Bit image command	US * +nH +nL +data	1F 2A +nH +nL +data	256*nH +nL defines how many bytes of bit image data will follow. See Section 4.2.2.5 - Bit Image (BI) Graphics Mode.
Set Page Length	US C +nH +nL	1F 43 +nH +nL	Sets the page length to 256*nH +nL dot lines. Default is 11 inches. Overwrites the page length set by ESC C.
Eject/retract ticket	US E	1F 45 +n	Bit 0 of n = 0 sets the mode to RETRACT an untaken ticket back into the printer. Bit 0 of n = 1 sets the mode to EJECT an untaken ticket out the front of the printer. See DIP SWITCH 2 position 2 for the default.
Set timeout to use before an untaken ticket is purged	US K	1F 4B +n	If a document is cut and presented (but not removed) and another document is sent to the printer, the first document will not be purged (either Ejected or Retracted) until +n seconds after the first document is presented. Default is 5 second.
Global IEEE-1284 STATUS Enable / Disable	US S +n	1F 53 +n	Low order nibble of +n = 0 disables all STATUS transmissions in IEEE-1284 parallel mode. Low order nibble of +n = 1 thru F enables STATUS transmission. Default is disabled.

Name	Command ASCII	Command hex	Description
Start of Document for WINDOWS	US b	1F 62	Used only by Telpar's Windows drivers. See Section 4.2.2.4 - Telpar's Window Commands.
End of Document for WINDOWS	US e	1F 65	Used only by Telpar's Windows drivers. See Section 4.2.2.4 - Telpar's Window Commands.
Set horizontal Print Position	US x +nH +nL	1F 78 +nH +nL	The horizontal print position is set to $(256 * nH + nL) * 8$ dots from the left margin. See Section 4.2.2.5 - Bit Image (BI) Graphics Mode.
Set Relative Vertical move	US y +nH +nL	1F 79 +nH +nL	Causes paper to feed $256 * nH + nL$ dot lines. See Section 4.2.2.5 - Bit Image (BI) Graphics Mode Commands.
Set Horizontal Print Position ABSOLUTE	US A	1F 41	Sets the x-move function (see US x +nH +nL) to be a move relative to the left margin. See US R.
Set Horizontal Print Position RELATIVE	US R	1F 52	Sets the x-move function (see US x +nH +nL) to be a move relative to the current position. Default setting. See US A.

4.2.2 Descriptions of Commands

4.2.2.1 Status commands

All transmission of status in IEEE-1284 mode is disabled at power on. Status transmission must be enabled by the US S +n command before any STATUS transmission will occur in IEEE-1284 mode.

In case of an ERROR as defined in the table below, the printer transmits DLE E and the 2 status bytes. The response to a STATUS REQUEST is to transmit DLE (10hex) followed a SOURCE byte that distinguishes what type of status is being transmitted followed by the two status bytes as defined in the table below.

The SOURCE byte is defined as:

A = Auto Status Back. Is disabled by default but is enabled when the printer receives the DLE A +n1 +n2 command. +n1 and +n2 define a mask using the same byte/bit structure as in the table below. A "1" in a bit position enables the automatic transmission of DLE A and the 2 status bytes when an enabled condition occurs. The bit positions marked as errors in the table will always cause the automatic transmission of DLE E and the 2 status bytes so these positions will usually be "0" in the user defined mask.

B = Buffered status. DLE B and the 2 status bytes are transmitted when the DLE B command is processed out of the input buffer.

R = Real Time Status. If enabled by US R +n command, DLE R and the 2 status bytes are transmitted immediately when the DLE R command is received by the printer.

U = not a true STATUS request. When DLE U +n1 +n2 is processed out of the receive buffer, the printer transmits DLE U +n1 +n2 back to the host. The user can send DLE U +n1 +n2 anywhere within a document if he needs to know that the printer has processed the document up to that point.

First Status byte transmitted (and MASK for DLE A command)		
Bit	Type	Function/condition
7	Status	Spare
6	Status	Spare
5	Status	Receive buffer is full
4	ERROR	Cutter Error
3	Status	Printer Busy
2	Status	Receipt Taken
1	Status	Receipt Dropped
0	ERROR	Delivery Jam

First Status byte transmitted (and MASK for DLE A command)

Second Status byte transmitted (and MASK for DLE A command)		
Bit	Type	Function/condition
7	Status	Spare
6	Status	Print head over temperature
5	Status	Spare Sensor
4	Status	Paper Low
3	Status	Cutter Home
2	Status	Paper at Delivery
1	ERROR	Paper Out
0	ERROR	Head Up

Printer's response to a STATUS REQUEST command

4.2.2.2 Set Print Mode

ESC ! +n [1B 21 +n]

+n is defined as	
Bit	Function
7	Not used.
6	Not used.
5	0 = Double high print OFF. 1 = Double high print ON.
4	0 = Double wide print OFF 1 = Double wide print ON.
3	Not used.
2	Not used.
1	Font size.
0	Font size.

Set Print Mode Table		
Bit 1	Bit 0	Font size (WxH)
0	0	FontB (10x30)
0	1	FontA (12x30)

Table 1 - Set Print Mode Table

Both double wide and double high can be selected for either character size. When a printed line contains characters with different heights, the characters are arranged so that the baseline of all characters lines up. Default = 00hex (Font B, 10 x 30 matrix) for MTP-2222. Default = 01hex (Font A, 12 x 30 matrix) for MTP-2232 and MTP-2242

4.2.2.3 Printer Reset

ESC @ [1B 40]

Initializes the printer.

Any data received before the ESC @ but not yet printed is cleared. The character size is set to the default font. Left and Right Margins are set to the defaults. Reverse video is turned off. Underline printing is turned off. Bar code height is set to 64. Bar code magnification is set to 2.

4.2.2.4 Telpar's Window Commands.

The Begin Document (US b) and End Document (US e) commands were created for use by the Telpar Windows driver. These two commands should not be sent to the printer by any other application program since unexpected results will occur.

4.2.2.5 Bit Image (BI) Graphics Mode Commands

BI US * +nH +nL +data 1F 2A +nH +nL +data

256*nH +nL defines how many bytes of bit image data will follow. The data is received sequentially with the first byte representing the first 8 dot positions at the top left side of the bit image with bit 7 being to the left and bit 0 being to the right as printed.

XMOVE US x +nH +nL 1F 78 +nH +nL

The horizontal print position is set to (256*nH + nL) * 8 dots from the left margin.

If there is a lot of white space on the current dot line, the XMOVE command can cause the print location pointer to be moved resulting in less data required to define a dot line of bit image data to be printed. Anytime there is more than 4 bytes of white space (32 dots) the XMOVE command will result in less data being sent to the printer. Another BI command can follow the XMOVE command until a YMOVE signifies the end of the current dot line.

YMOVE US y +nH +nL 1F 79 +nH +nL

Causes paper to feed 256*nH + nL dot lines. This is also the BI line terminator and print command.

4.2.2.6 Print Bar Code Command

GS k +m +n +d1~dn [1D 6B +m +n (DATA)]

+m selects the bar code type. +n defines the number of data bytes which follow.

If more data is sent than can fit on the printer being used, the bar code is not printed.

+m	Bar code	+n	Valid data	Comment
41	UPC-A	11	0-9	Checksum generated & printed
42	UPC-E	7	0-9	Checksum generated & printed
43	EAN13	12	0-9	Checksum generated & printed
44	EAN8	7	0-9	Checksum generated & printed
45	Code39	variable	0-9 A-Z sp \$%*-./	
46	ITF	variable.	0-9	If an odd number of data bytes is sent, a leading zero will be added.
47	CODABAR	variable.	0-9 - \$: / . +ABCD	
49	CODE128	variable.	See Section 4.2.2.7 - Bar Code 128 definitions	
4A	CODE 39	variable.	0-9 A-Z sp \$%*-./	Checksum generated & printed
4B	ITF	variable.	0-9	Checksum generated & printed. If the data sent and the checksum causes an odd number of digits, a leading zero will be printed.

4.2.2.7 Bar Code 128 definitions

Code128 Character set: 103 data chars, three different start characters, and a unique stop character.

CodeA consists of the ASCII characters 00hex thru 5Fhex, FNC1 thru FNC4, Shift, CodeB, and CodeC.

CodeB consists of the ASCII characters 00hex thru 7Fhex, FNC1 thru FNC4, Shift, CodeA, and CodeC.

CodeC consists of 2 digit numeral characters 00dec thru 99dec, FNC1, CodeA, and CodeB.

The 103 different bar code patterns have different meanings depending on whether CodeA, CodeB, or CodeC was specified when the data was received. The data string must start with {A or {B or {C to specify CodeA, CodeB, or CodeC. A checksum is calculated and printed by the printer.

Value used to calculate checksum	CodeA	CodeB	CodeC		Value used to calculate checksum	CodeA	CodeB	Code C
0	(sp)	(sp)	00		54	V	V	54
1	!	!	01		55	W	W	55
2	"	"	02		56	X	X	56
3	#	#	03		57	Y	Y	57
4	\$	\$	04		58	Z	Z	58
5	%	%	05		59	[[59
6	&	&	6		60	\	\	60
7	'	'	07		61]]	61
8	((08		62	^	^	62
9))	09		63	_	_	63
10	*	*	10		64	00hex	`	64
11	+	+	11		65	01hex	a	65
12	,	,	12		66	02hex	b	66
13	-	-	13		67	03hex	c	67
14	.	.	14		68	04hex	d	68
15	/	/	15		69	05hex	e	69
16	0	0	16		70	06hex	f	70
17	1	1	17		71	07hrx	g	71
18	2	2	18		72	08hex	h	72
19	3	3	19		73	09hex	i	73
20	4	4	20		74	0Ahex	j	74
21	5	5	21		75	0Bhex	k	75
22	6	6	22		76	0Chex	l	76
23	7	7	23		77	0Dhex	m	77
24	8	8	24		78	0Ehex	n	78
25	9	9	25		79	0Fhex	o	79
26	:	:	26		80	10hex	p	80
27	;	;	27		81	11hex	q	81
28	<	<	28		82	12hex	r	82
29	=	=	29		83	13hex	s	83
30	>	>	30		84	14hex	t	84
31	?	?	31		85	15hex	u	85

4.3 Serial (RS-232C) Interface

4.3.1 Serial (RS-232C) Interface Specification

Serial (RS-232C) Interface Specification	
Item	Specification
Data receive speed	Baud rate selected at factory (written in flash). Default baud rate is 115200 bps. Default Data Bits = 8, default Stop Bits = 1, Default Parity = none
Synchronizing method	Asynchronous, Full duplex
Handshake	Hardware or XON/XOFF
Input output level	RS-232C
Signal level	Space (logic=0) +3 V ~ +12 V Mark (logic=1) -3 V ~ -12 V

04.3.2 Serial I/O Connector

Location of J9, the Serial Port RS-232 Connector, on the Printer's main circuit board. **Pins 1-9 (odds) are bottom row, left to right. Pins 2-8 (evens) are top row, left to right.**



RS-232 Connector, J9 Pinout

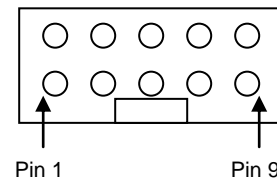

Pin 1 Pin 9

Mates with .1"X.1" Socket Connector

J9 Pin #	Function:
1	NA
2	DTR Data Terminal Ready, Output from printer)
3	TxD (Transmit Data, Output from printer)
4	CTS (Clear To Send, Input to Printer)
5	RxD (Receive Data, Input to Printer)
6	RTS (Request To Send, Output from Printer)
7	DSR (Data Set Ready, Input to Printer)
8	NA
9 & 10	Circuit Common

4.3.3 Optional MTP Serial Adapter Cable (Telpar Part Number 800410-0015):

For customers who wish to connect to the printer with the traditional 9 Pin D-Sub Connector, Telpar offers an MTP Serial Adapter Cable as shown below. This 3 ½" long cable plugs into the J9 serial connector on the main circuit board and has enough length to exit the printer chassis (as shown below) for external connections to a cable. The pinout for the D-Sub connector is shown in the table below.

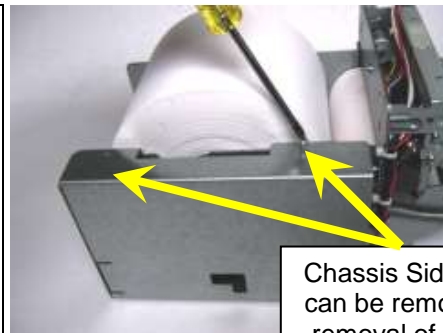
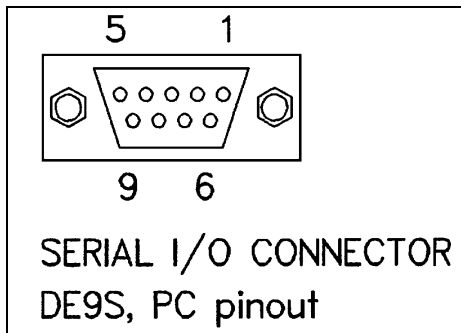
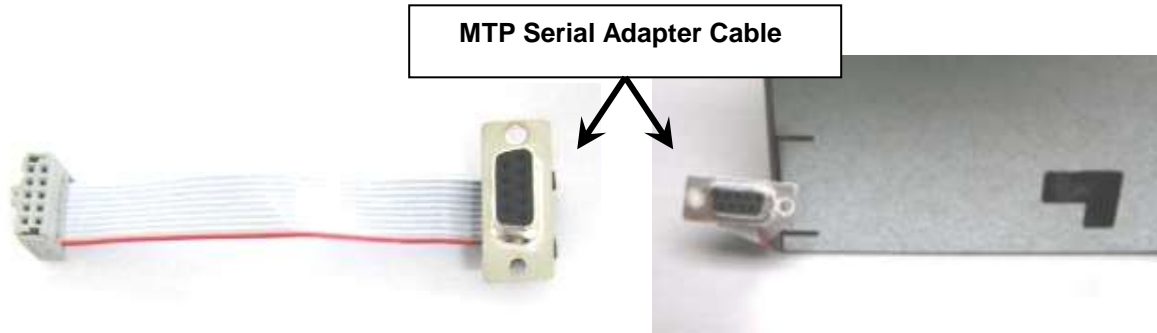

D-Sub Connector Serial (RS-232C) Interface Pinout			
Pin	Name	Direction	Function
2	RD	I	RS232 received data.
3	XD	O	RS232 transmitted data.
4	DTR	O	Hardware handshake line.
5	GND	-	Logic ground.
6	DSR	I	The state of DSR is IGNORED for XON/XOF handshaking if selected.

4.4 Parallel Interface (IEEE-1284)

4.4.1 Parallel I/O Connector

Location of J5, the Parallel Port Connector, on the Printer's main circuit board. **Pins 1-25 (odds) are bottom row, left to right. Pins 2-26 (evens) are top row, left to right.**

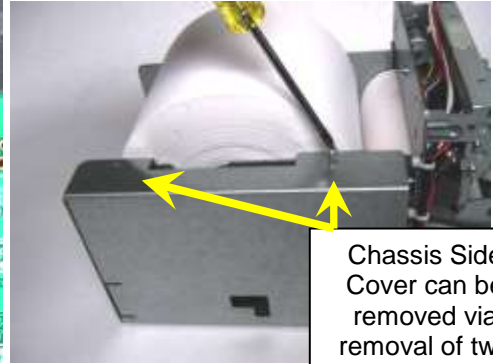
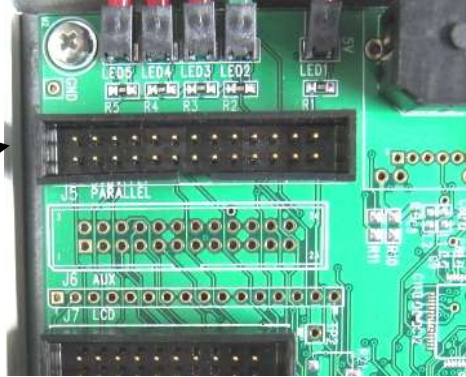

Chassis Side Cover can be removed via removal of two top screws as shown

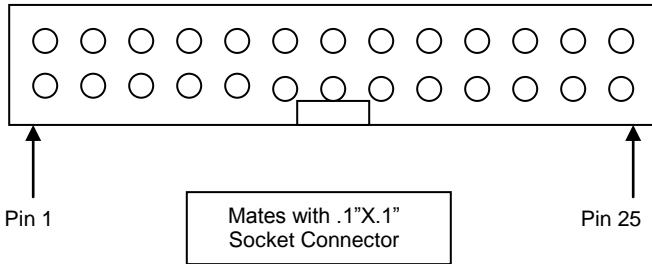

Parallel Port Connector, J5 Pinout (See Table Below also)

J5 Pin #	Function	J5 Pin #	Function
1	/STB, Active Low Pulse to send data to printer	14	Circuit Common
2	AFXT, HostAck, Input to Printer	15	IO6, ASCII data bit 6, Bi-directional
3	IO0, ASCII data bit 0 (LSB), Bi-directional	16	Circuit Common
4	/ERR, Low level output = Printer Error	17	IO7, ASCII data bit 7 (MSB), Bi-directional
5	IO1, ASCII data bit 1, Bi-directional	18	Circuit Common
6	/INIT, Low level resets printer	19	/ACK, Active low pulse when data is accepted
7	IO2, ASCII data bit 2, Bi-directional	20	Circuit Common
8	/SLCTIN, Low level enables printer	21	BUSY, High level when printer cannot accept data
9	IO3, ASCII data bit 3, Bi-directional	22	Circuit Common
10	Circuit Common	23	PE, High level when printer is out of paper
11	IO4, ASCII data bit 4, Bi-directional	24	Circuit Common
12	Circuit Common	25	SLCT, High level when printer is on
13	IO5, ASCII data bit 5, Bi-directional	26	Circuit Common

4.4.2 Optional MTP Parallel Adapter Cable (Telpar Part Number 800180-1012):

For customers who wish to connect to the printer with the traditional 25 Pin D-Sub Connector, Telpar offers an MTP Parallel Adapter Cable as shown below. This 6" long cable plugs into the J5

parallel connector on the main circuit board and has enough length to exit the printer chassis (as shown below) for external connections to a cable. The pinout for the D-Sub connector is shown in the table below.

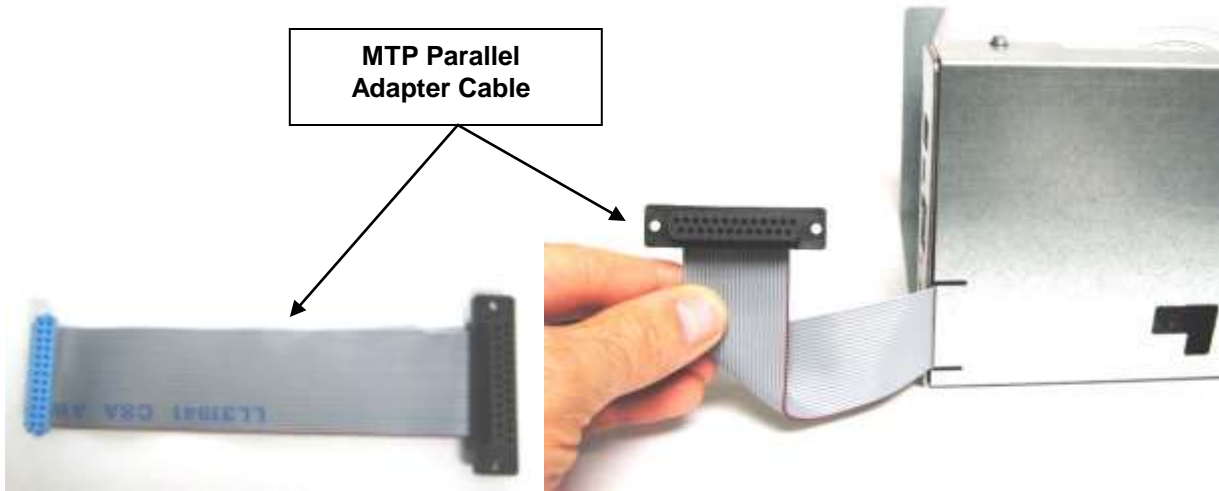

Parallel Interface Pin Assignments				
J2 Pin#	Name	Cent. Name	Direction	Function in Centronics Mode (SPP)
1	PeripheralAck	BUSY	O	High level when printer cannot accept data.
2	Xflag	SLCT	O	High level when printer is on.
3	PeripheralClk	/ACK	O	Active low pulse when data is accepted
4	-PeripheralReq	/ERR	O	Low level when an error occurs.
5	-AckRev	PE	O	High level when printer is out of paper
6	IO0	DO	I/O	ASCII data bit 0 (LSB)
7	IO1	D1	I/O	ASCII data bit 1
8	IO2	D2	I/O	ASCII data bit 2
9	IO3	D3	I/O	ASCII data bit 3
10	IO4	D4	I/O	ASCII data bit 4
11	IO5	D5	I/O	ASCII data bit 5
12	IO6	D6	I/O	ASCII data bit 6
13	IO7	D7	I/O	ASCII data bit 7
14	-RevReq	/INIT	I	Low level = system reset.
15	HostClk	/STB	I	Active Low Pulse to send data to printer
16	1284Active	/SLCTIN	I	Low level enables printer.
17	HostAck	AFXT	I	
18	HostLogicHigh		I	Host Logic High
19 thru 35		GND	-	Logic ground.
36	PeriphLogicHigh		O	Peripheral Logic High.
Shell	CGND	CGND	-	Chassis ground

4.5 USB Interface

The current location of the USB 2.0 Mini-B connector for all MTP series printers is located next to the barrel

power jack as shown below.

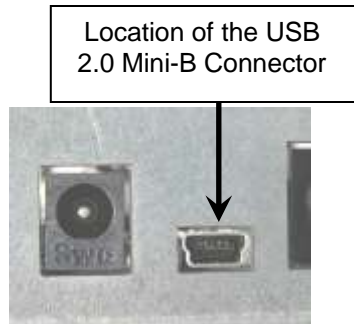

4.6 Ethernet Interface (Currently under development)

The ability to connect the MTP series of printers to the Ethernet is currently being developed and will be available shortly.

4.7 Printer Drivers

Printer Drivers for Microsoft® Windows® Operating Systems can be downloaded from our website at www.telpar.com.

Microsoft® and Windows® are registered trademarks of Microsoft Corporation.

5 Detailed Specifications

5.1 MTP-2822, MTP-2832 and MTP-2242 Detailed Specifications

General Specifications				
Specifications		MTP-2822	MTP-2832	MTP-2242
Printing method		Thermal-sensitive line dot method		
Dot Structure		432 dots/line	576 dots/line	832 dots/line
Dot pitch (horizontal)		0.125 mm (8 dot/mm)-Dot density		
Dot pitch (vertical)		0.125 mm (8 dot/mm)-Line feed pitch		
Effective printing area		54 mm (2.13")	72 mm (2.84 ")	104 mm (4.09")
Paper width		60 mm (2.362 ")	80 mm (3.15 ")	114 mm (4.49")
Paper thickness		0.0024 to 0.0039 inches		
Cutting type		Full or partial (Software control)		
Number of columns (default)		36 columns/line (12 x 24 dot font)	48 columns/line (12 x 24 dot font)	69 columns/line (24X12 dot font)
Maximum printing speed		1000 dot line/s (125 mm/s)		640 dot line/s (80 mm/s)
Interface		IEEE-1284 Parallel, RS-232C Serial, USB 2.0		
Power Supply	For head	See Section 1.3 - Power Supply Requirements.		
	For motor	DC 24V± 5%, 1.0 A max., <0.1A typical		
	For cutter	DC 24V± 5%, 1.2 A max.	DC 24V± 5%, 1.0A max	
Expected Life	Mechanism	Pulse durability: 1x10 ⁸ pulse/dot (standard driving method) Wear resistance: 100 km (at 12.5% printing ratio)		
	Cutter	5 x 10 ⁹ cuts for MTP-2222 and MTP-2232, 3 x 10 ⁵ cuts for MTP-2242		
Environmental conditions	Operating temp.	0 to +50°C		
	Operating humidity	20 to 85% RH (No condensation)		
	Storage temp.	-20 to +60°C		
	Storage humidity	5 to 95% RH (No condensation)		
Detection	Head temp.	By thermistor (applied energy control, abnormal temperature detection)		
	Paper Out/Mark detect	By photointerrupter		
Paper		Thermal Sensitive paper		

5.2 MTP-2283 Detailed Specifications

Specifications		MTP-2283
Printing method		Thermal-sensitive line dot method
Dot Structure		2400 dots/line
Dot pitch (horizontal)		0.00333 inch (300 dot/inch)-Dot density
Dot pitch (vertical)		0.00333 inch (300 dot/inch)-Line feed pitch
Effective printing area		8 inches
Paper width		8.5 inches
Paper thickness		0.0024 to 0.0039 inches
Cutting type		Full cut only
Number of columns (default)		80 columns/line (30 x 50 dot font)
Maximum printing speed		600 dot line/s (50 mm/s)
Character composition, dimensions (W x H), Number of characters per line		30 x 50 dots, 2.54 x 4.23 mm, 80 columns 18 x 38 dots, 1.52 x 3.22 mm, 133 columns
Interface		IEEE-1284 Parallel and RS-232C Serial
Power Supply	For head	See Section 1.3.2
	For motor For cutter	DC 24V± 5% DC 24V± 5%, 1.0 A max.
Expected Life	Mechanism	Pulse durability: 1x10 ⁸ pulse/dot Wear resistance: 50 km
	Cutter	5 x 10 ⁵ cuts
Environmental condition	Operating temperature	0 to +50°C
	Operating humidity	20 to 85% RH (No condensation)
	Storage temperature	-20 to +60°C
	Storage humidity	5 to 95% RH (No condensation)
Detection	Head temperature	By thermistor (applied energy control, abnormal temperature detection)
	Paper out/Mark detect	By reflective photo assembly
Paper		Thermal Sensitive paper

5.3 Character Sets - Print Samples

MTP-2242 CHARACTER SET
 PC437 (Standard U.S.A)
 ESC t 00hex

```

0123456789ABCDEF
20  !"#$%&'()*+,-./
30  0123456789:;<=>?
40  @ABCDEFGHIJKLMNO
50  PQRSTUVWXYZ[]^_
60  `abcdefghijklmno
70  pqrstuvwxyz{|}~
80  ÇüéâääåçêëèïîÏÄÅ
90  ÉæÆôöòûÿÿÏÛø£¥f
A0  áíóúñÑæøç-½¼i«»
B0  ::::|}|{|}|||}||}
C0  L|_|_|_|_|_|_|_|_|_|
D0  |_|_|_|_|_|_|_|_|_|
E0  αβΓπΣσμτφθΩδ∞ΦεΠ
F0  ≡±≥≤|}÷÷°••√n2■
    
```

Code Page 437 Print sample

MTP-2242 CHARACTER SET
 PC850 (Multilingual)
 ESC t 02hex

```

0123456789ABCDEF
20  !"#$%&'()*+,-./
30  0123456789:;<=>?
40  @ABCDEFGHIJKLMNO
50  PQRSTUVWXYZ[]^_
60  `abcdefghijklmno
70  pqrstuvwxyz{|}~
80  ÇüéâääåçêëèïîÏÄÅ
90  ÉæÆôöòûÿÿÏÛø£Ø×f
A0  áíóúñÑæøç-½¼i«»
B0  ::::|}|{|}|||}||}
C0  L|_|_|_|_|_|_|_|_|_|
D0  ðÐÊËÈË íîï|ì
E0  ÓβÔÒõÕμρΡÚÛÜýÝ´
F0  -±¼¶§÷¸°·¹²³■
    
```

Code Page 850 Print sample

MTP-2242 CHARACTER SET

Default per DIP switch 2 or as changed by
 ESC R +n = INTERNATIONAL CHARACTER SET

+n	hex	23	24	40	5B	5C	5D	5E	60	7B	7C	7D	7E
0 USA	#	\$	@	[\]	^	`	{		}	~	
1 France	#	\$	à	°	ç	§	^	`	é	ù	è	¨	
2 Germany	#	\$	§	Ä	Ö	Ü	^	`	ä	ö	ü	ß	
3 England	£	\$	@	[\]	^	`	{		}	~	
4 Denmark	#	\$	@	Æ	Ø	Å	^	`	æ	ø	å	~	
5 Sweden	#	¤	É	Ä	Ö	Å	Ü	é	ä	ö	å	ü	
6 Italy	#	\$	@	°	\	é	^	ù	à	ò	è	ì	
7 Spain	¤	\$	@	í	Ñ	¿	^	`	¨	ñ	}	~	
8 Japan	#	\$	@	[¥]	^	`	{		}	~	
9 Norway	#	¤	É	Æ	Ø	Å	Ü	é	æ	ø	å	ü	
10 Denmark 2	#	\$	É	Æ	Ø	Å	Ü	é	æ	ø	å	ü	
11 Spain 2	#	\$	á	í	Ñ	¿	é	`	í	ñ	ó	ú	
12 LatAmer	#	\$	á	í	Ñ	¿	é	ü	í	ñ	ó	ú	
13 Korea	#	\$	@	[₩]	^	`	{		}	~	

International Character Sets

5.4 MTP-2822 Standard Printer Drawing

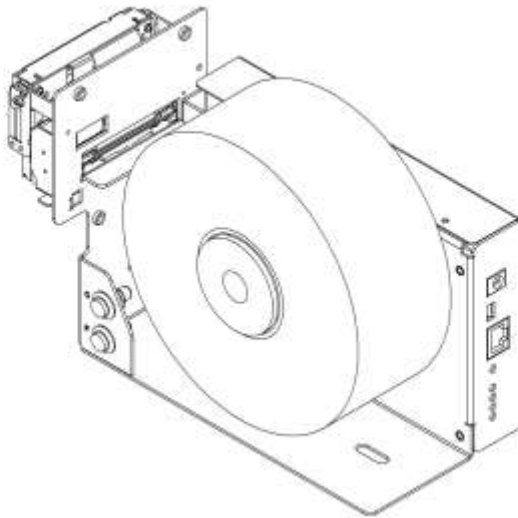
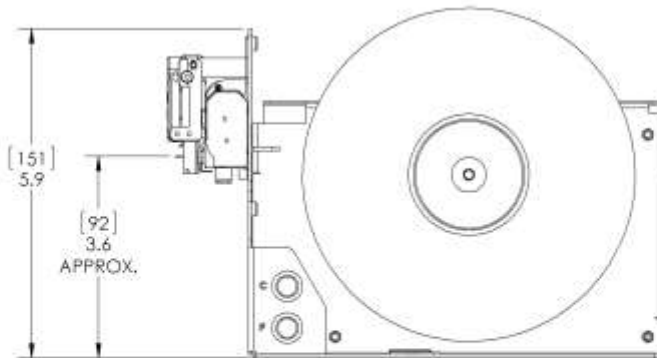
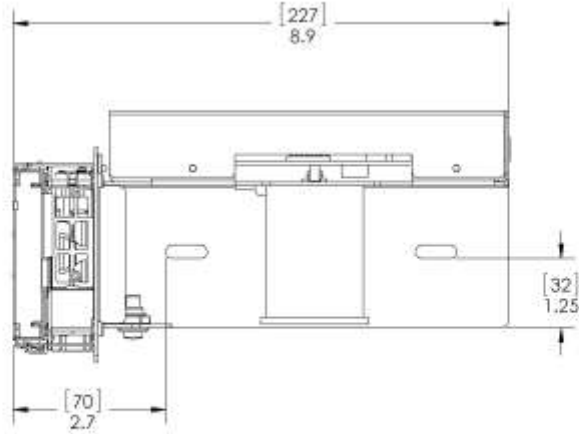

MTP-2822 Presenter Printer Drawing

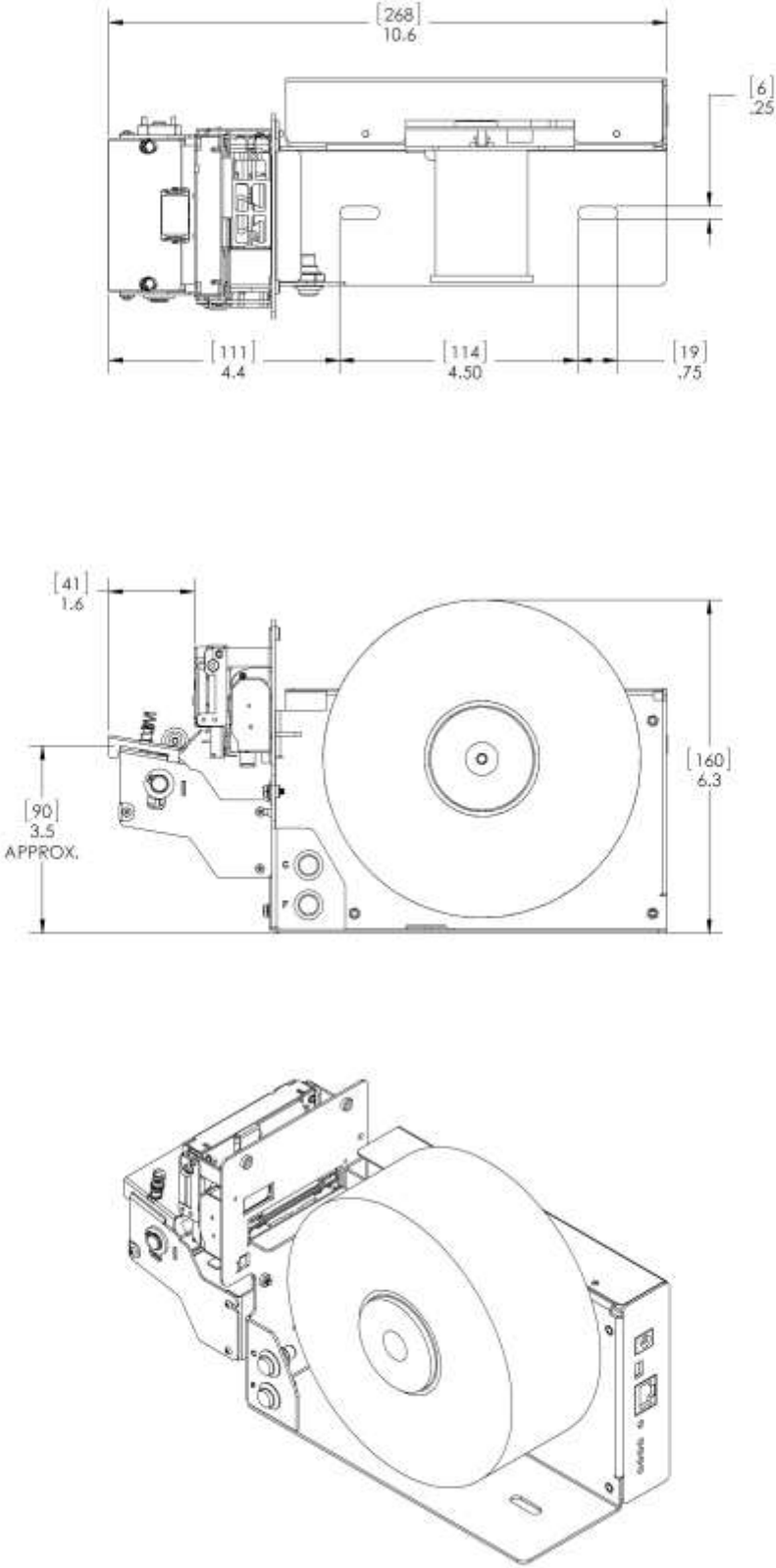

5.5 MTP-2832 Standard Printer Drawing

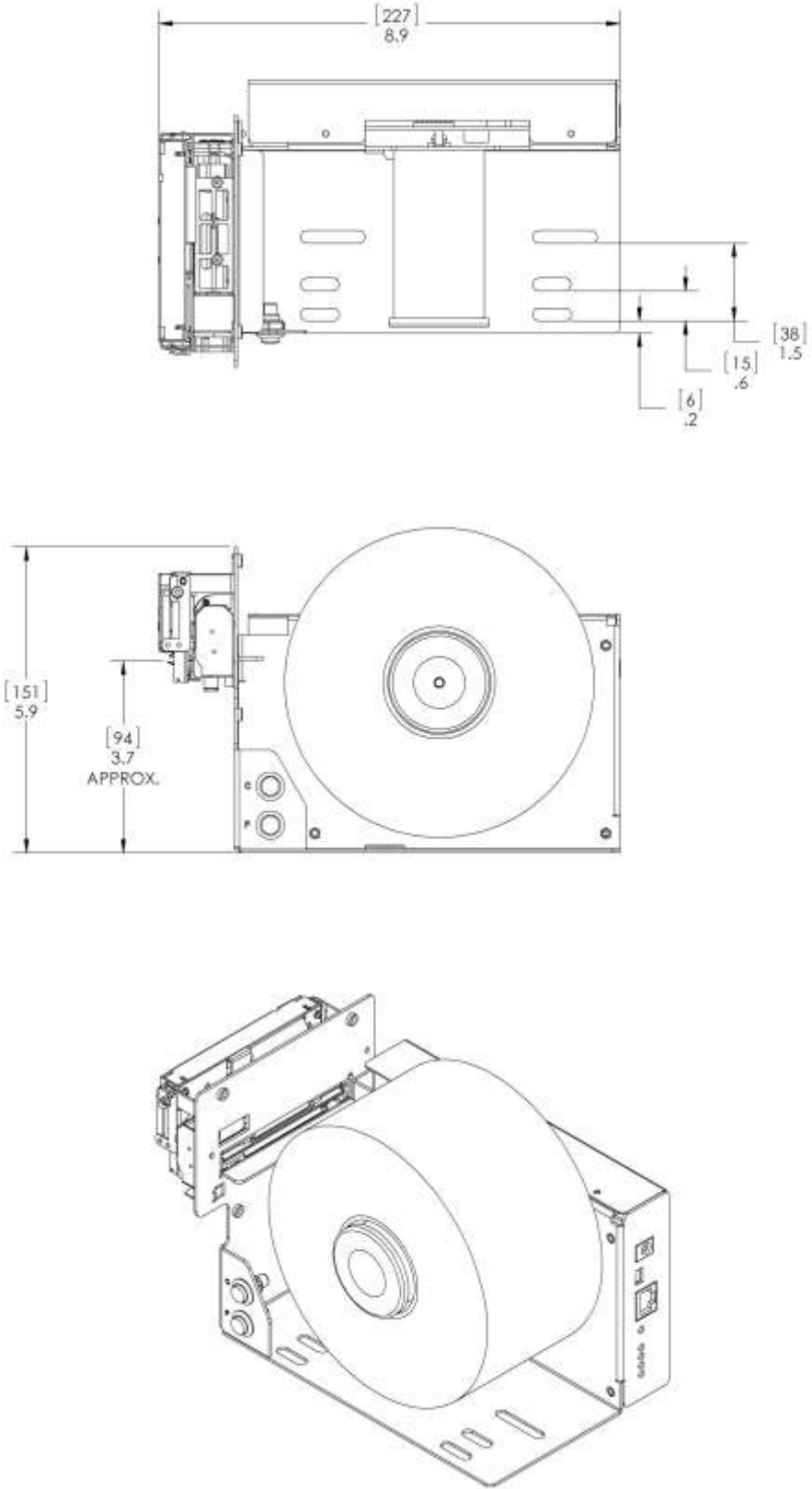

MTP-2832 Presenter Printer Drawing

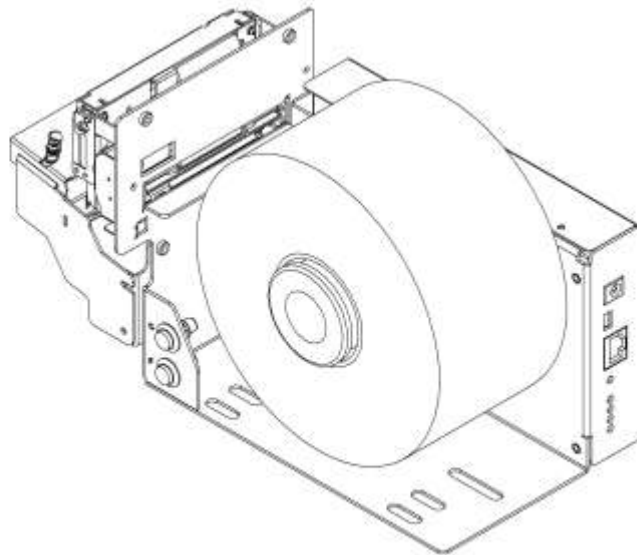
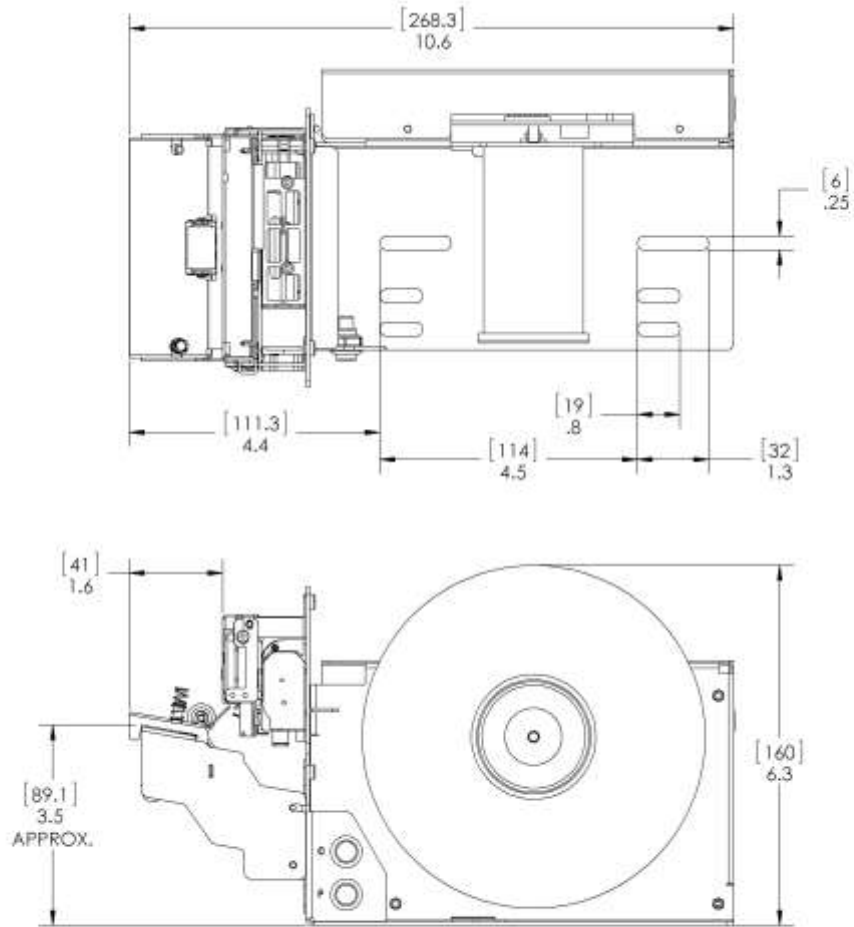

5.6 MTP-2242 Standard Printer Drawing

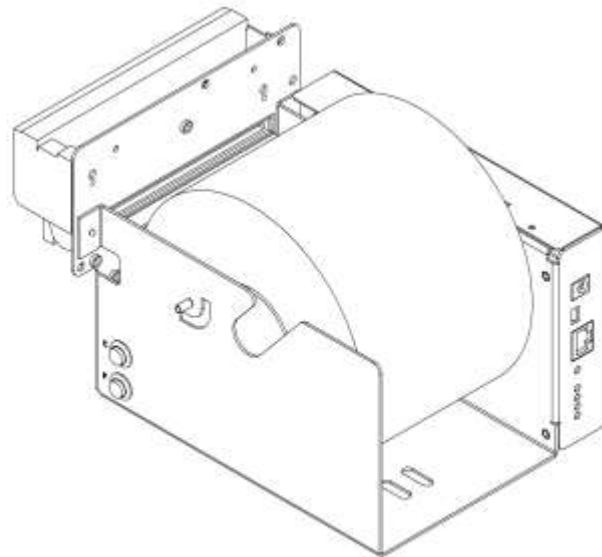
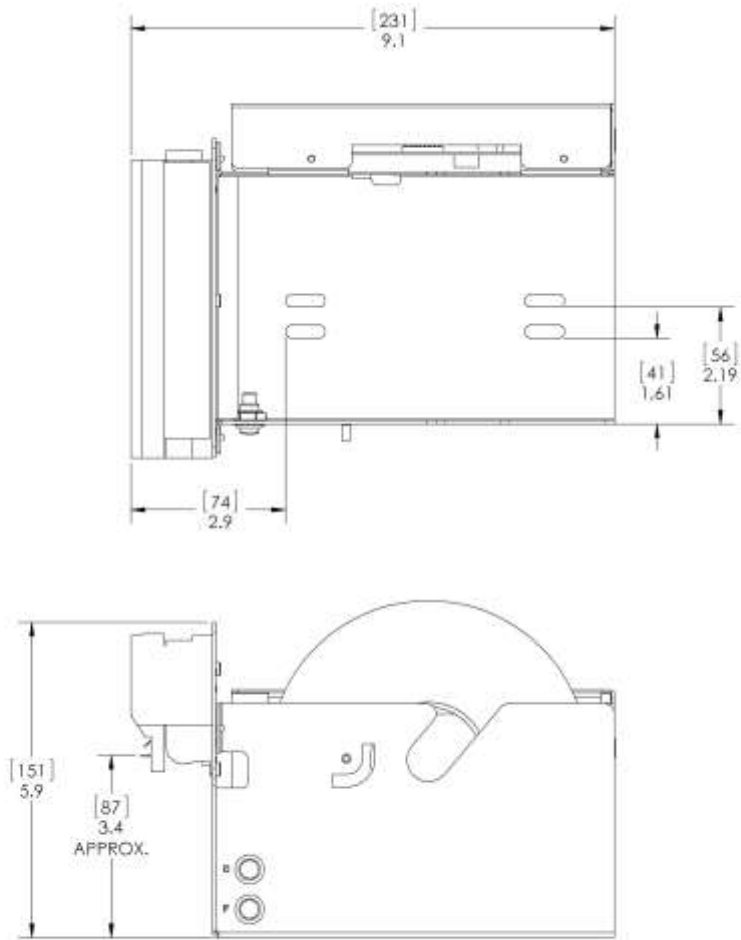

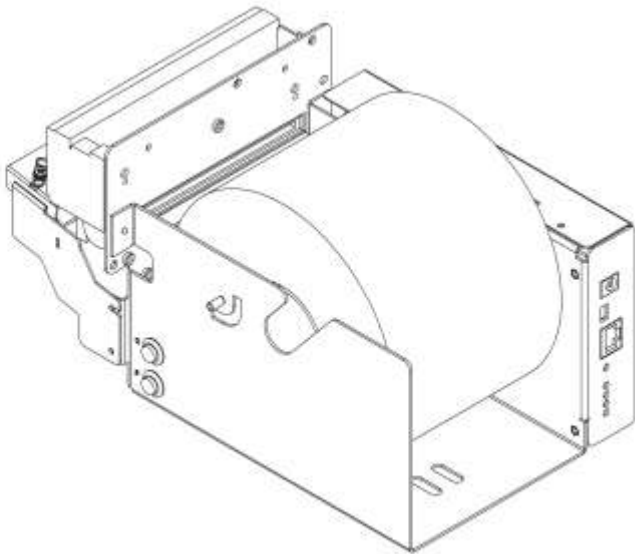
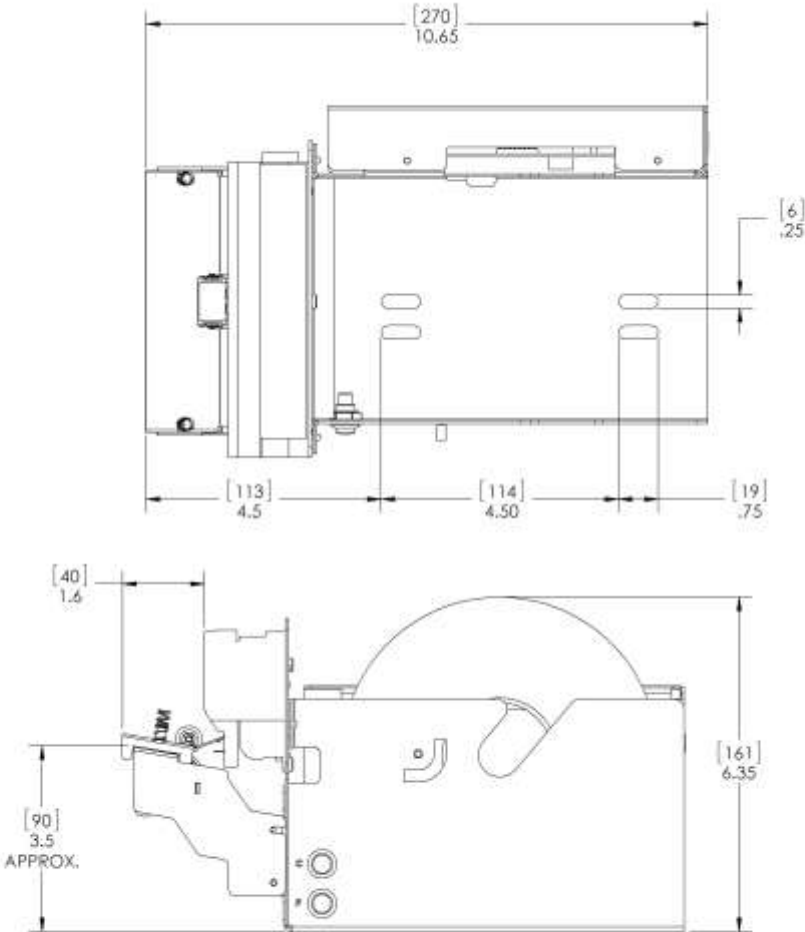

MTP-2242 Presenter Printer Drawing

5.7 MTP-2283 Standard Printer Drawing

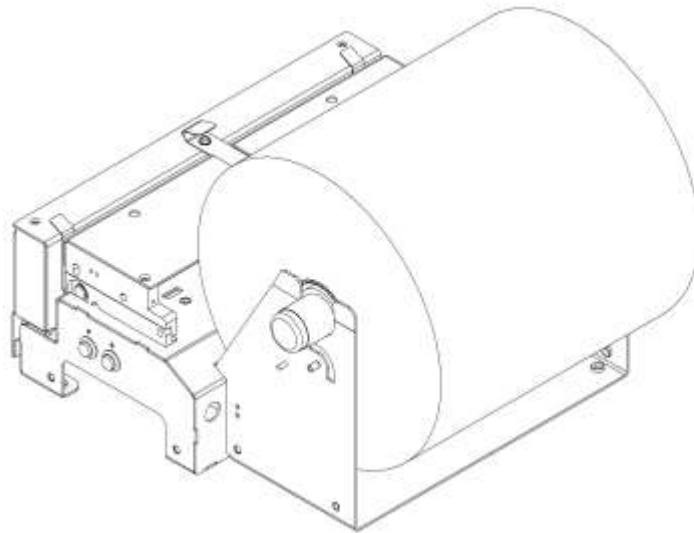
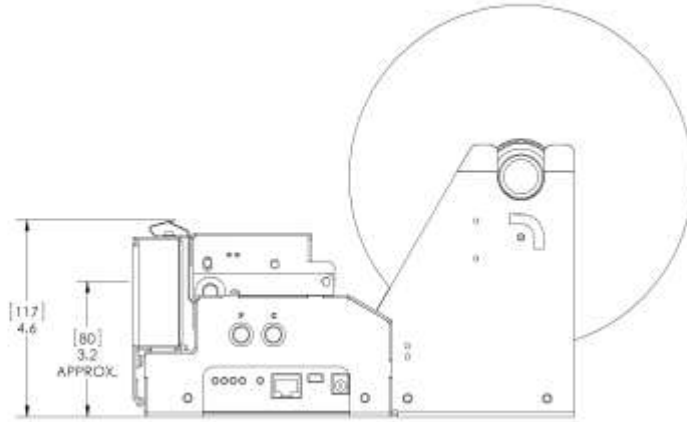
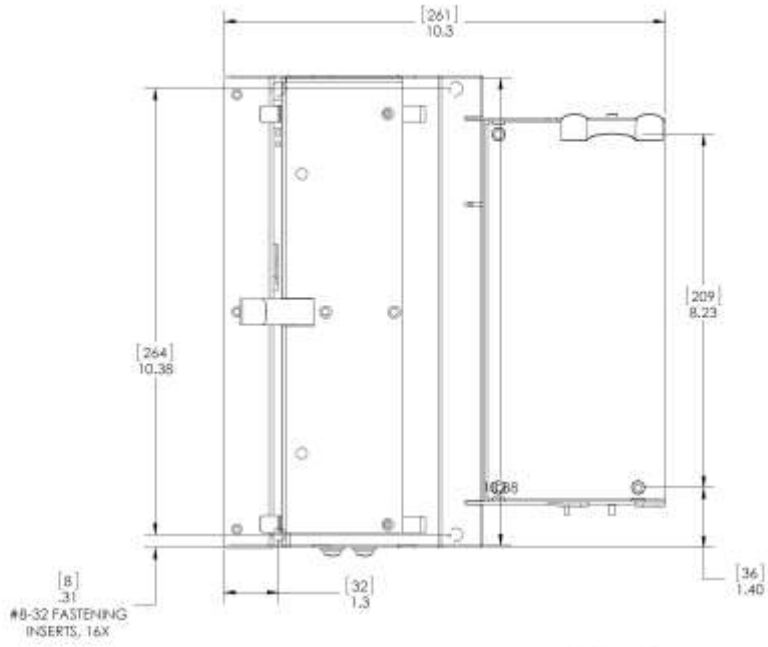

MTP-2283 Presenter Printer Drawing

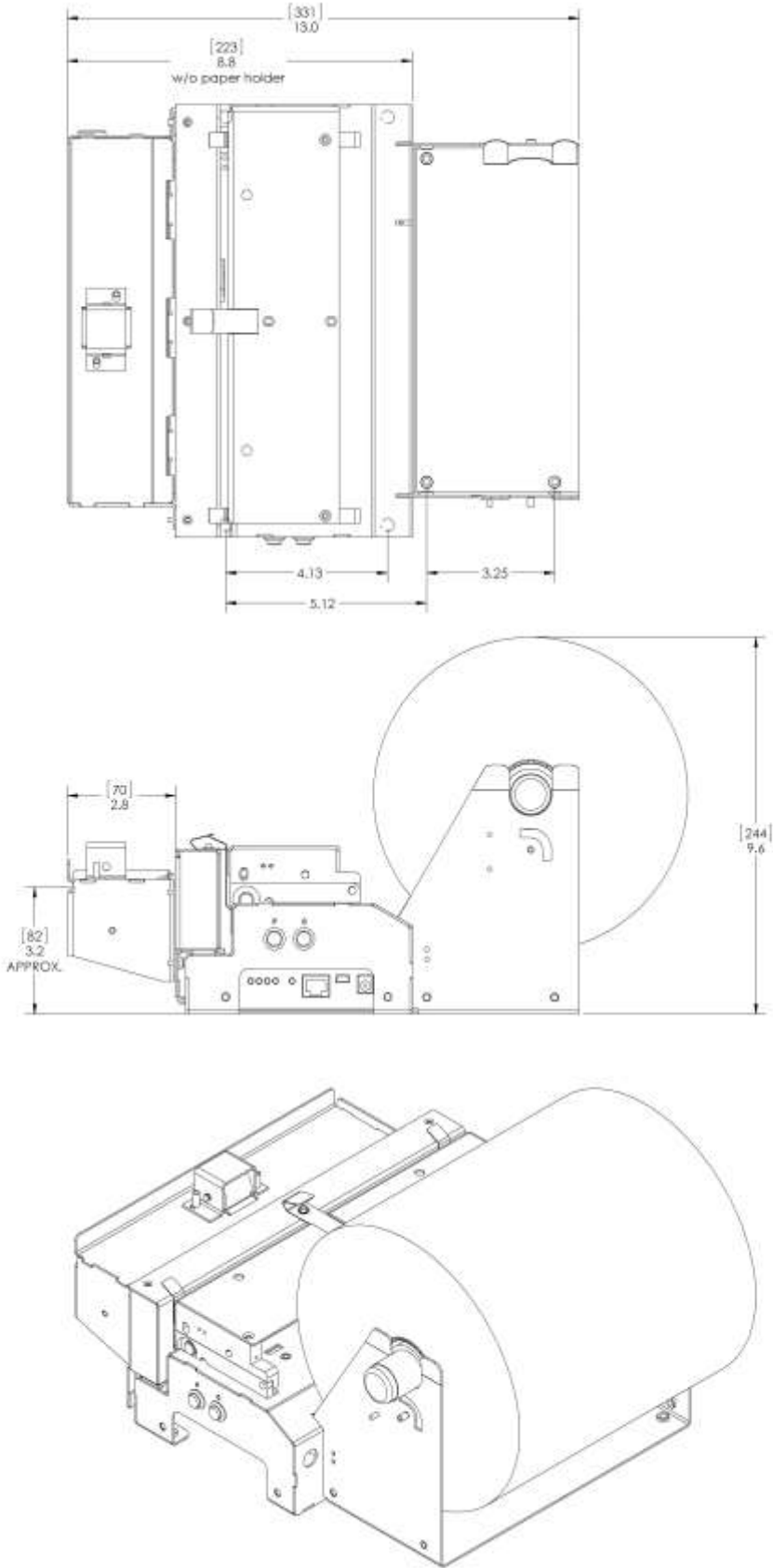

6 Troubleshooting

6.1 General Troubleshooting

Printer does not seem to do anything → Check the following:

- ❑ Printer is plugged into an active power source with the correct voltage and current ratings
- ❑ Power supply – Is it active or switched to the 'ON' position (if applicable)?
- ❑ Is the main circuit board getting power? Check the Red 5 Volt Power LED (See Section 6.2 below). If the 5 Volt Power LED is not lit, and an approved external power supply that is known to be working correctly is being used, then the main circuit board on the printer has probably failed. Call Telpar Technical support for assistance.
- ❑ Is the printer's print head or Head Up lever in its fully closed position? These printers will not attempt to print unless the print-head is fully and securely closed.
- ❑ Is the main circuit board's DIPSWITCH, position 1 switch in the "Up" or ON position? If so, slide the switch to the OFF position and cycle printer power. The printer will not print with this switch on (flash memory upload mode).

Printer feeds paper and performs a Self Test but does not print from the host (computer, controller, etc.) → Check the following:

- ❑ Communications Cable – is the correct type of cable being used, and is it securely connected?
- ❑ Is the correct printer driver installed on the host (if required)?
- ❑ Is the printer connected to the same port that was selected when installing the printer driver?
- ❑ Is the host's printer port 'Ready' or 'OFFLINE'? Is there a conflict with another printer on that port?

Printer's Document Presenter, Cutter and/or Paper Low Status not working as expected / General unexpected printer operation / Unexpected Printer Error → check the following:

- ❑ Are the printer's DIP Switch's on the main circuit board correctly set for your application? Remember, whenever any DIPSWITCH positions are changed, the power to the printer must be cycled for the change to take effect.
- ❑ Is the printer's print head or Head Up lever in its fully closed position? These printers will not attempt to print unless the print-head is fully and securely closed.
- ❑ Printer is plugged into an active power source with the correct voltage and current ratings.
- ❑ Sensors are clean (free of paper dust or other unwanted obstructions). Clean sensors by blowing pressurized air over the sensor face.

Printer presents a blank document (nothing is printed on the ticket) or the printing is too light → check the following:

- ❑ In case of a blank document: verify that the roll of paper is Thermal Paper (not plain paper) and that the paper is fed into the printer with the **thermal side up** (this is the most common cause for receiving a blank document as only one side of a roll of thermal paper is printable typically).
- ❑ In the case of the print appearing too light: check the setting of the darkness control adjustment (R35 on the Main Circuit Board – Print Density). Try rotating the adjustment clockwise to darken the print. It is recommended that the darkness level be increased to the point that just meets the desired darkness level under the normal ambient operating conditions for the printer application – this will help extend the life of the print head element.

Printer prints gibberish when sending Serial Information to the Printer (apparent random

characters) → check the following:

- ❑ The default factory settings for the MTP Series serial protocol is printers is 15,200 bps (baud rate), 8 Data Bits, 1 Stop Bit, No Parity. The Host controller (computer, PLC, etc.) must be set to the same settings as the printer in order for the printer to print correctly.

Paper jams in Printer or Presenter → check for the following: (ALWAYS KEEP FINGERS AND TOOLS AWAYS FROM CUTTER BLADES!)

- ❑ Obstructions in the paper path (including the paper presenter loop if a presenter is used – it is very important that the paper loop that forms below the presenter section does not physically contact anything)
- ❑ Misalignment of the paper path. This is possible if the printer's original paper roll holder is not being used, but rather a different design has been implemented that allows the paper roll to be located away from or outside of the printer. If this is the case, you must make sure your design maintains a reliably aligned paper path from the paper roll location to the printer.
- ❑ Is Incorrect or out-of-spec paper is being used? Paper that is not to the paper specifications for your printer increases the chances of having repetitive paper jams.
- ❑ An Inoperable document cutter or damaged cutter blades not fully opening or closing.
- ❑ Is the Customer allowed to pull the exiting document before the printer is done printing or cutting? This is a common jam scenario. To avoid this possibility, specify the document presenter option by added to your printer when ordering.

Printer suddenly stops and does not respond unless the power switch is cycled → check the following: (ALWAYS KEEP FINGERS AND TOOLS AWAYS FROM CUTTER BLADES!)

- ❑ Is there a paper jam condition? Are cutter blades not fully open (if applicable)?
- ❑ Check the Diagnostic / Error LEDs and use the table below to interpret the problem the printer is reporting. See if the problem can be corrected based on the printer's diagnostic feedback.
- ❑ Possible dirty or defective paper sensors or Print-head Latch Switch. In the case of dirty sensors obstructed by dust or paper fragments, clean sensors by blowing pressurized air over the sensor face.

6.2 LED Diagnostics and Error Detection Codes:

Five LED's are located on the printer as shown below. These LED's have the following functions:

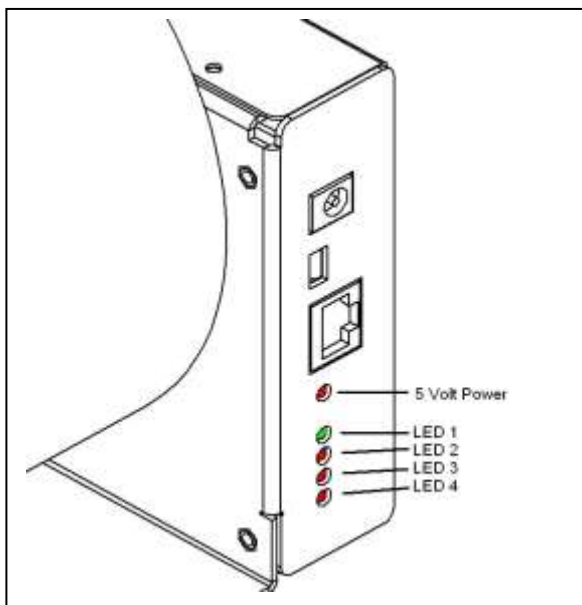

Power LED: The Top most LED Indicates 5 Volt power is present

LED 1 Indicates the Printer is Ready when blinking.

LED 2 provides PAPER_LOW and PAPER_OUT status.

- Blinking indicates Paper Low Status.
- ON indicates Paper Out Status.

LED 3 & 4 Provide error status (see table below)

6.3 LED Error Code Definitions Table

Certain ERROR codes are reported when they occur by a sequence of blinks of LEDs 3 and 4 located on the controller board. The ERROR BLINK patterns are listed below. This table is also printed during a self test.

LED 3 blinks ON four times indicated in the table below as T1, T2, T3, and T4. Following each sequence of blinks there is a pause before repeating the sequence. The ON times of LED 3 is the time base used for encoding the error reporting by LED 4. LED 4 blinks ON during some of the four times that LED 3 blinks ON. The pattern of ON times of LED 4 listed in the table below indicates the ERROR being reported. The printer's audio beeper will also sound a long tone at the same time LED 4 is ON.

		T1 LED 3 Blinks ON	T2 LED 3 Blinks ON	T3 LED 3 Blinks ON	T4 LED 3 Blinks ON	
Error Number	Error Code	LED 4 status below	LED 4 status below	LED 4 status below	LED 4 status below	Description
1	Paper Out	Blinks ON	OFF	OFF	OFF	Printer is out of paper.
2	Head Up	OFF	Blinks ON	OFF	OFF	Printer head is in the up position.
3	Paper Jam	Blinks ON	Blinks ON	OFF	OFF	Paper is jammed in printer.
4	Cutter Fault	OFF	OFF	Blinks ON	OFF	Cutter is not functioning.
5	Delivery Jam	Blinks ON	OFF	Blinks ON	OFF	Paper is jammed at the delivery.
6	Abort Printing	OFF	Blinks ON	Blinks ON	OFF	Printing aborted due to unrecoverable error
7	Over Temp Warning	Blinks ON	Blinks ON	Blinks ON	OFF	Print head is above maximum temperature.

END OF MANUAL